



*DeviceNet.*

# ***Cable Guide***

**Open DeviceNet Vendor Association, Inc. (ODVA)**

PMB 499 • 20423 State Road 7 #F6 • Boca Raton, FL 33428-6797

Phone: (1) 954 340-5412 • Fax: (1) 561 340-5413

e-mail: [odva@powerinternet.com](mailto:odva@powerinternet.com) • Web: [www.odva.org](http://www.odva.org)



*DeviceNet™*



Because of the variety of uses for the products described in this publication, those responsible for the application and use of this control equipment must satisfy themselves that all necessary steps have been taken to assure that each application and use meets all performance and safety requirements, including any applicable laws, regulations, codes and standards.

The illustrations, charts, sample programs and layout examples shown in this guide are intended solely for example. Since there are many variables and requirements associated with any particular installation, the Open DeviceNet Vendor Association, Inc. (O.D.V.A.) does not assume responsibility or liability (to include intellectual property liability) for actual use based upon the examples shown in this publication.

Reproduction of the contents of this copyrighted publication, in whole or in part, without written permission of O.D.V.A. is prohibited.

Throughout this manual we make notes to alert you to possible injury to people or damage to equipment under specific circumstances.

Attentions help you:

- identify a hazard
- avoid the hazard
- recognize the consequences

**Important:** Identifies information that is especially important for successful application and understanding of the product.

**Important:** We recommend you frequently backup your application programs on appropriate storage medium to avoid possible data loss.

## Using This Manual

### What's In This Manual

Use this manual to plan and install a DeviceNet cable system. This manual describes the required components of the cable system and how to plan for and install these required components.

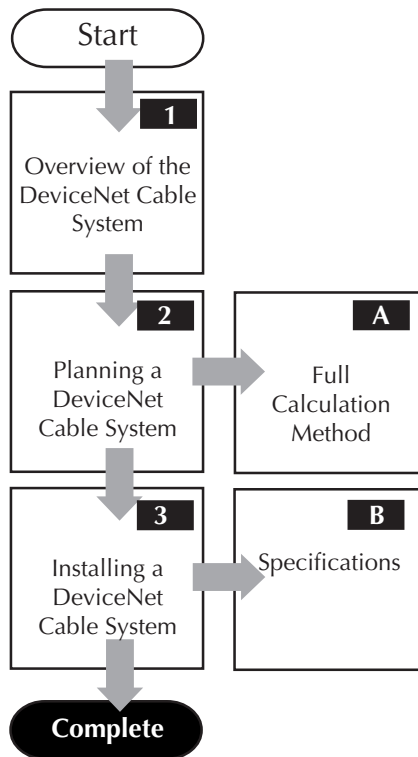

We assume that you have a fundamental understanding of:

- electronics and electrical codes
- basic wiring techniques
- ac and dc power specifications
- load characteristics of the devices attached to the DeviceNet network

### National Electric Code

Much of the information provided in this manual is representative of the capability of a DeviceNet network and its associated components. The National Electric Code (NEC), in the United States, and the Canadian Electric Code (CECode), in Canada, places limitations on configurations and the maximum allowable power/current that can be provided.

The instructions and examples in this manual are based on Class 2 power supplies.

**Important:** Be sure that all national and local codes are thoroughly researched and adhered to during the planning and installation of your DeviceNet network.



## Overview of the DeviceNet Cable System

## Chapter 1

What's in This Chapter	1-1
Understanding the DeviceNet Cable System	1-1
Referring to the Cables	1-1
Understanding the Cable System's Components	1-2
Thick Cable	1-3
Thin Cable	1-3
Connecting to the Trunk Line	1-4
Tee Tap	1-5
Junction Box Tap	1-5
Power Tap	1-6
Direct Connection	1-6
Connectorized Tap	1-7
Using Connectors	1-8
Using Preterminated Cables	1-9
Thick Cable	1-9
Thin Cable	1-9
Connecting to a Tee Tap from a Sealed Device	1-10
Connecting to a Junction Box Tap from a Sealed Device	1-10
Using Terminating Resistors	1-11
What's Next	1-11

## Planning a DeviceNet Cable System

## Chapter 2

What's in This Chapter	2-1
Understanding Topologies	2-2
Guidelines for Supplying Power	2-2
Determine the Maximum Cable Distance	2-2
Determine the Cumulative Drop Line Length	2-3
Power Ratings	2-4
Locating a Power Supply	2-5
Locating a Power Supply	2-6
Using the Look-Up Method	2-7
Maximum Allowable Current	2-8
One Power Supply (End Segment) Thick Cable	2-8
Segment Between Two Power Supplies Thick Cable	2-9
End Segment in Two Power Supply System Thick Cable	2-10
One Power Supply (End-Segment) thin	2-11
One Power Supply (End-Connected)	2-12
One Power Supply (Middle-Connected)	2-13
Adjusting the Configuration	2-14
NEC/CECode Current Boost Configuration	2-15
Two Power Supplies (End-Connected)	2-16
Two Power Supplies (Not End-Connected)	2-17
Two Power Supplies (Not End-Connected)	2-18



<b>Planning a DeviceNet Cable System</b>	<b>Chapter 2</b>
Choosing a Power Supply	2-19
Sizing a Power Supply	2-20
Grounding the Cable System	2-21
Terminating the Cable System	2-22
What's Next	2-22

<b>Installing a DeviceNet Cable System</b>	<b>Chapter 3</b>
What's in This Chapter	3-1
Installing a DeviceNet Cable System	3-1
Preparing Cables	3-1
Using Pinouts	3-2
Connecting Drop Lines	3-3
Connecting Power Supplies	3-4
Grounding the Cable System	3-5
Terminating the Cable System	3-6
Applying Power	3-7

<b>Full Calculation Method</b>	<b>Appendix A</b>
What's in This Appendix	A-1
Supplying Power	A-1
Adjusting the Configuration	A-1
Using the Equation	A-2
One Power Supply (End-Connected)	A-3
One Power Supply (Middle-Connected)	A-4
One Power Supply (Middle-Connected)	A-5
One Power Supply (Middle-Connected)	A-6
One Power Supply (Middle-Connected)	A-7

<b>Selected NEC Topics</b>	<b>Appendix B</b>
What's in This Appendix	B-1
Specifying Section 725 Topics	B-1

<b>Troubleshooting DeviceNet</b>	<b>Appendix C</b>
Examine the System Design of the Installation	C-1
Check the power	C-1
Check the wiring	C-1
Points to remember	C-2
Check the scanner configuration	C-3
Check the nodes	C-3

## Overview of the DeviceNet Cable System

### What's in This Chapter

Read this chapter to familiarize yourself with the DeviceNet cable system.

For information on	See page
understanding the DeviceNet cable system	1-1
referring to the cables	1-1
understanding the cable system's components	1-2
connecting to the trunk line	1-4
using connectors	1-8
using preterminated connectors	1-8
using terminating resistors	1-11
what's next	1-11

### Understanding the DeviceNet Cable System

This cable system uses a trunk/drop line topology:

For information on multiple nodes and branching on the drop line, see page 2-1.

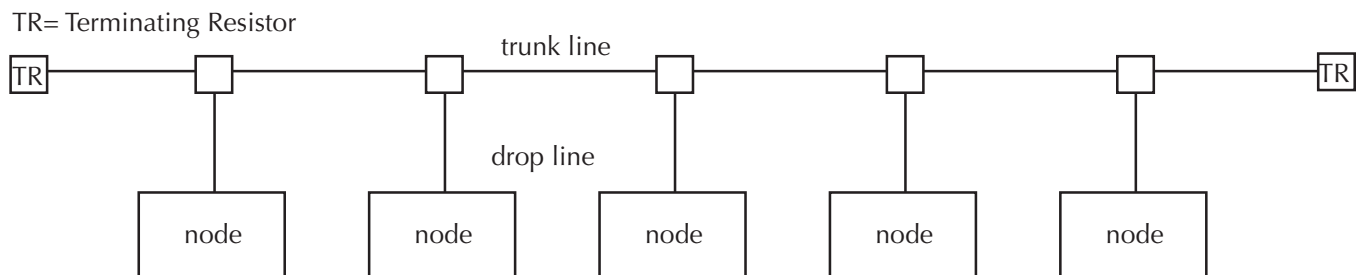

Trunk line and drop line lengths are determined by the communication rate used.

### Referring to the Cables

Connect components using two cables sizes:

This cable	Is used
thick	generally as the trunk line on the DeviceNet network with an outside diameter of 12.2mm (0.48in). You can also use this cable for drop lines.
thin	generally as the drop line connecting devices to the trunk line with an outside diameter of 6.9mm (0.27in). This cable has a smaller diameter and is more flexible. You can also use this cable for the trunk line.

## Understanding the Cable System's Components

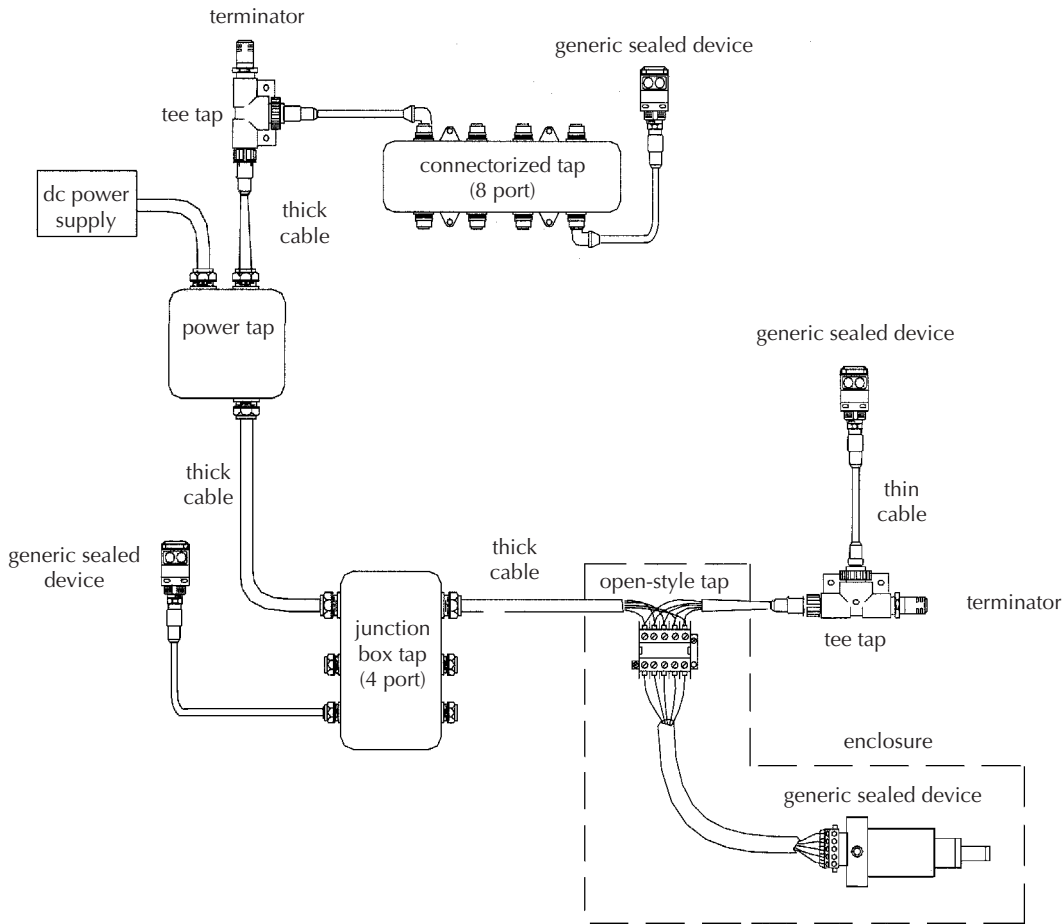

Component	Component	Component	Component
trunk line	the cable path between terminators that represents the network backbone -it is made up of thick or thin cable -connects to taps or directly to devices	tee tap	a single-port connection with sealed connectors
drop line	the drop line is made up of thick or thin cable -connects taps to nodes on the network	junction box tap	a junction box that allows 2,4, or 8 drop lines to connect to the trunk line
node/device	an addressable device that contains the DeviceNet communication circuitry	connectorized tap	a junction box with sealed connectors that allows 4 or 8 drop lines to connect to the trunk line
terminating resistor	the resistor (121Ω, 1% 1/4W or larger) attaches only to the ends of the trunk line	power tap	the physical connection between the power supply and the trunk line
open-style connector	used with devices not exposed to harsh environments	open-style tap	terminals that connect a drop line to the trunk line
sealed-style connector	used with devices exposed to harsh environments		

## Thick Cable

Thick cable, with an outside diameter of 12.2mm (0.48in), is generally used as the trunk line on the DeviceNet network.

*Thick cable can be used for trunk lines and drop lines.*

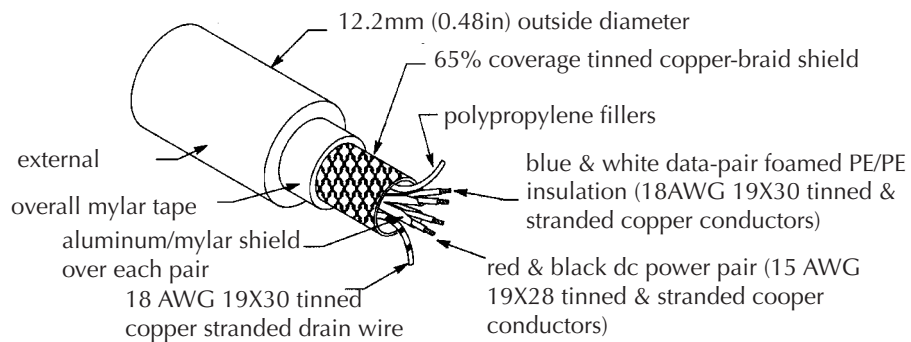

## Thin Cable

Thin cable, with an outside diameter of 6.9mm (0.27in), connects devices to the DeviceNet trunk line via taps.

*Thin cable can be used for trunk lines and drop lines.*

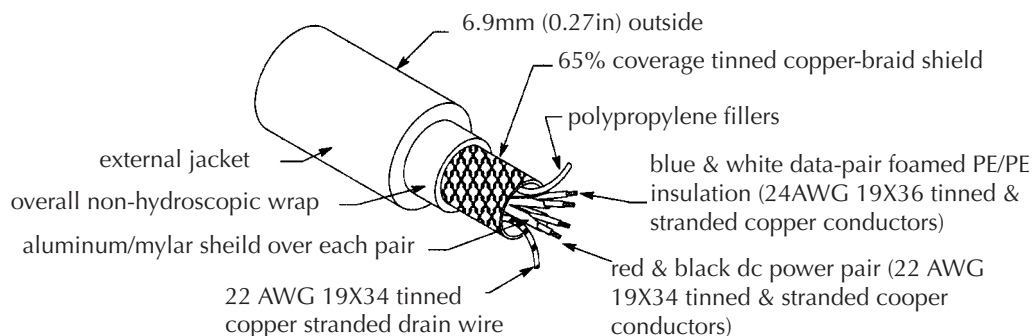

## Connecting to the Trunk Line

The cable system design allows replacement of a device without disturbing operation of the cable system.

**Important:** The trunk line must be terminated on each end with a 121Ω, 1/4W resistor. See page 1-11 for more information.

You can connect to the trunk line through a:

### Trunk-Line Connection

See page

### Trunk-Line Connection

See page

tee tap

1-5

junction box tap

1-5

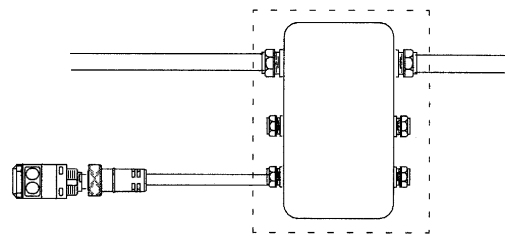
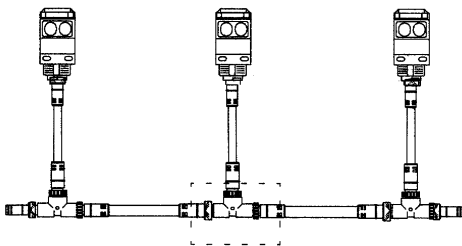

power tap

1-6

connectorized tap

1-7

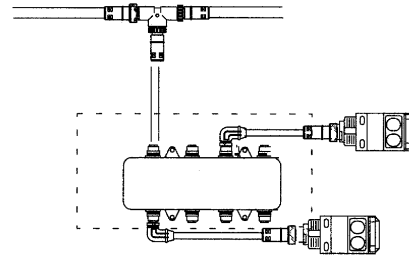
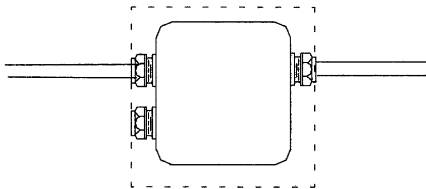

direct connection

1-6

1-6

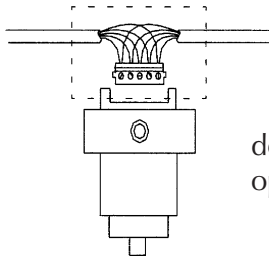

device with plug-in open-style connector

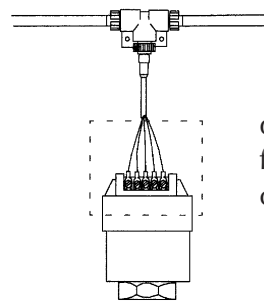

device with fixed open-style connector

## Tee Tap

The tee tap connects to the drop line with a mini or micro quick-disconnect style, right or left keyway for positioning purposes, as well as opposing genders on either side to allow back-to-back tee tap connections on the trunk line.

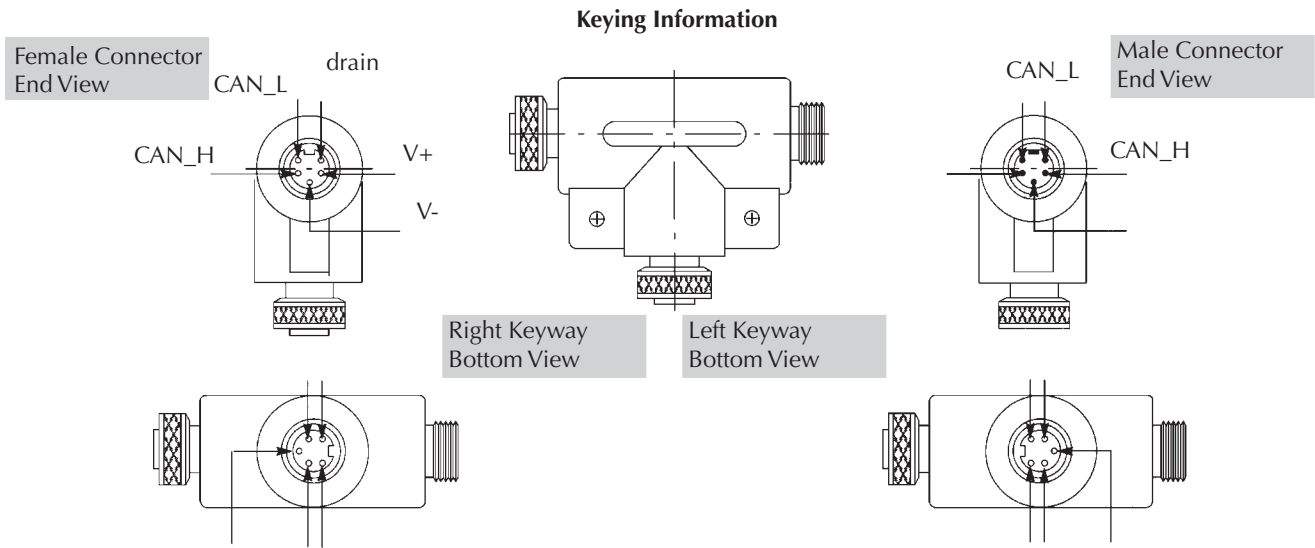

## Junction Box Tap

Junction box taps are a direct connection to the trunk line, providing terminal strip connections for up to 8 nodes using thin-cable drop lines. They have a removable gasket cover and cable glands to provide a tight, sealed box that can be mounted on a machine.

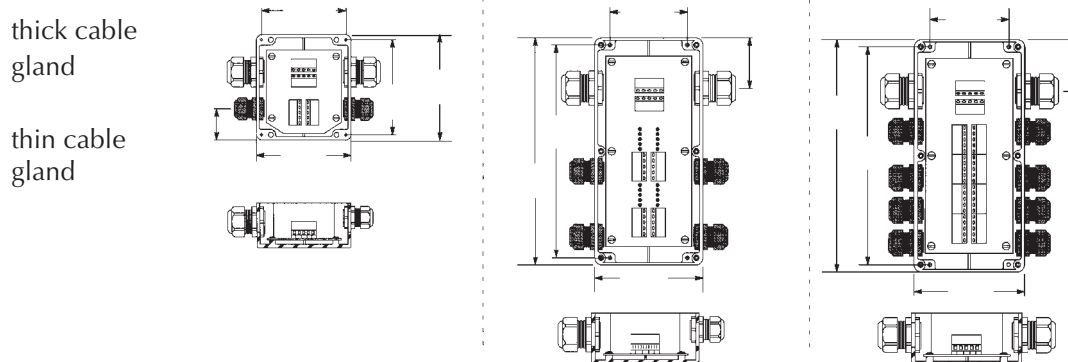

## Power Tap

The power tap can provide over current protection to the thick cable (country and/or local codes may prohibit use of the full capacity of the power tap). A power tap with diode can also be used to permit the connection of multiple power supplies to the trunk line without back-feeding between supplies.

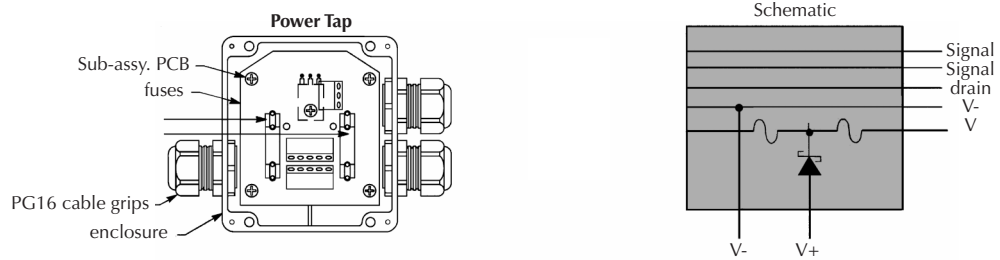

In cases where the power supply provides current limiting and inherent protection, fuses/overcurrent devices may not be necessary at the power tap.

## Direct Connection

Devices can be connected directly to the trunk line only if later removal of the device will not disturb communications on the cable system.

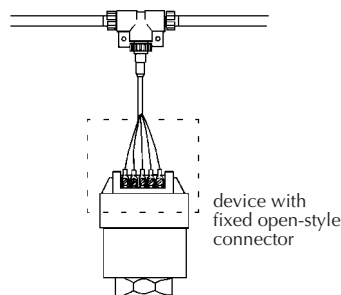

**Important:** If a device provides only fixed-terminal blocks for its connection, it must be connected to the cable system by a drop line. This allows removal of the device at the tap or device end of the drop line without disturbing communications on the cable system.

## Connectorized Tap

Connectorized taps are multipoint taps that connect to the trunk line via drop lines. You may use micro or mini-style connectors.

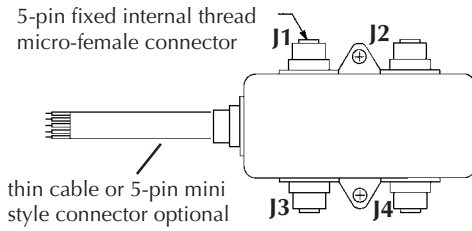

### 8-Port Connectorized Tap with 2m Drop Line

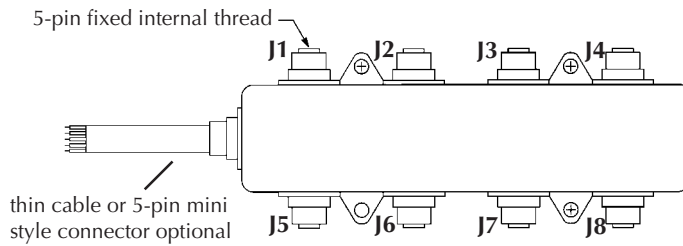

## Using Connectors

Connectors attach cables to other components of the DeviceNet cable system.

Connector		Description
open	pluggable	uses screws to attach cable wires to the removable connector
	hard-wire	uses wires to attach directly to screw terminals
sealed	mini-style	attaches to taps and thick or thin cable
	micro-style	attaches to thin cable only - has a reduced current rating

These are the field-installable connection options.

## Connection

micro or mini field-installable quick-disconnect

male plug



female plug



Screws or crimps the conductors of thick cables to contacts of the connectors with male or female-threaded plugs

5-pin linear plug with probe holes but without jack

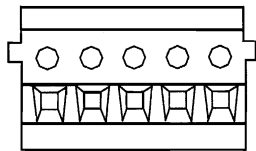

recommended for making connection to the end of thick or thin cable and drop line when the device has a mating header

10-pin linear plug with probe holes and jack

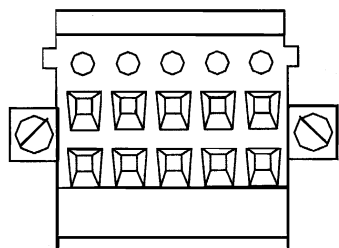

recommended for making a daisy-chain segment with thick or thin cable (available with or without jack screws) when device has mating header

## Using Preterminated Cables

Using preterminated cable assemblies saves you the effort of stripping and wiring connectors to the cable ends and reduces wiring errors.

### Thick Cable

Thick cable assemblies shorter than 6m (20ft) can also be used as drop lines.

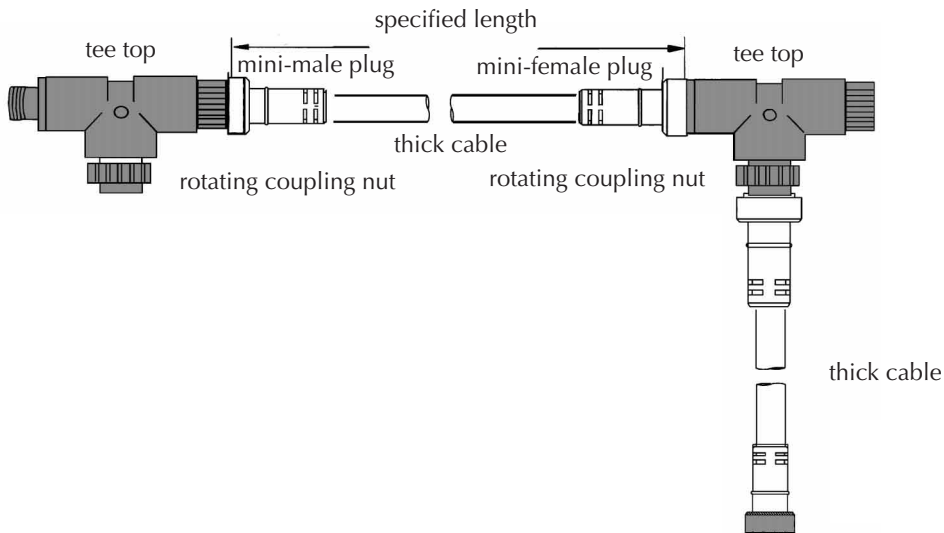

### Thin Cable

Preterminated thin cable assemblies for use as drop lines are available with various connectors in various lengths. Preterminated thin cable assemblies can also be used as trunk lines, provided the maximum cable distance does not extend beyond 100m.

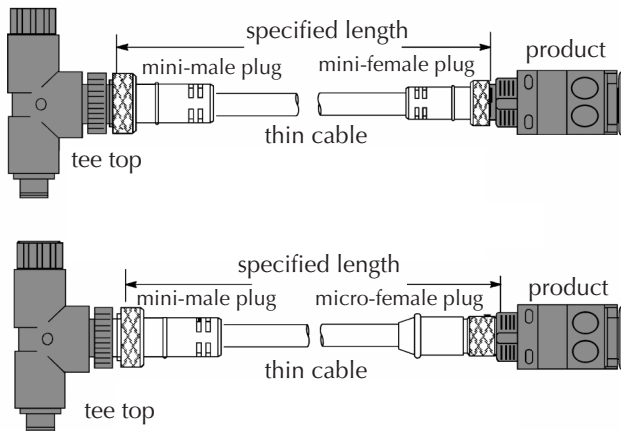

## Connecting to a Junction Box Tap from a Sealed Device

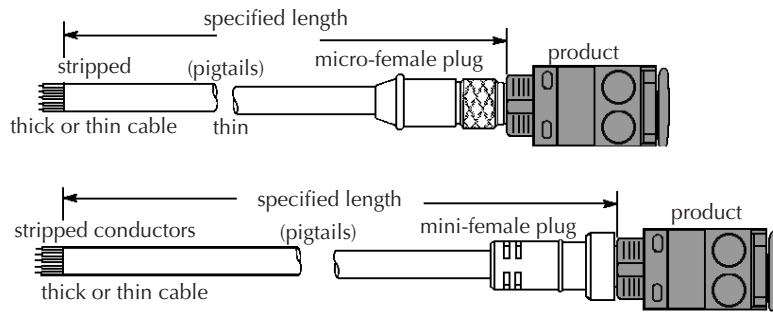

## Using Terminating Resistors

The trunk line of your DeviceNet network must have a resistor attached to each end that terminates the signal lines. The resistor:

- prevents reflection of communication signals on the network
- connects the two signal conductors
- may be sealed when the end node uses a sealed tee, or open when the end node uses an open-style tap

When using the open-style terminating resistor, connect a 121Ω, 1/4W resistor to the CAN\_H and CAN\_L between blue and white data-pair wires.

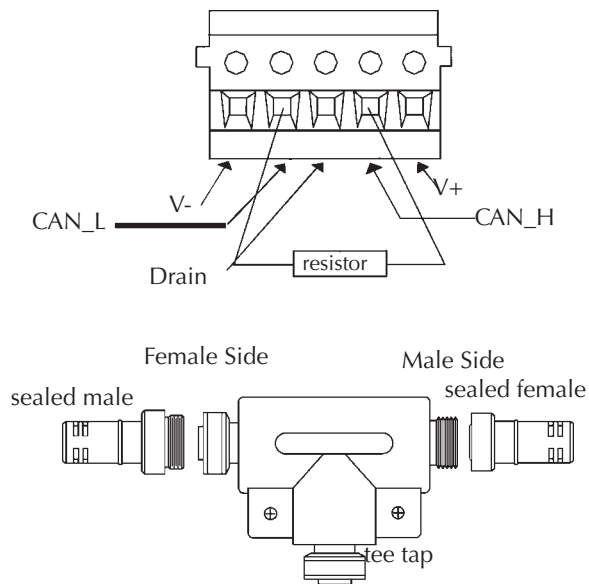

## What's Next

Now that you have seen the basic components of a DeviceNet cable system, you can begin planning the layout for your network components and the distribution of power to the network. Read the next chapter for requirements and considerations.

## Planning a DeviceNet Cable System

### What's in This Chapter

To plan your cable system, you need to know the specifications of your devices including how much current each node requires from the cable system. This chapter will show you how to calculate your power requirements and determine:

- power distribution
  - maximum current curves
  - current calculations
- effects of device distribution on your cable system
- power components needed to assemble a DeviceNet cable system

<b>For information on</b>	<b>See page</b>
understanding topologies	2-1
supplying power guidelines	2-2
determining the maximum cable distance	2-2
determining the cumulative drop line length	2-3
understanding power ratings	2-4
locating a power supply	2-5
using the look-up method	2-6
choosing a power supply	2-19
grounding the cable system	2-21
terminating the cable system	2-22
what's next	2-22

### Understanding Topologies

- \* The maximum cable distance from any device on a branching drop line to the trunk line is 6m (20ft).
- \* The trunk line must be terminated at both ends with a 121Ω terminating resistor.
- \* The maximum cable distance is not necessarily just the trunk line length. It is the maximum distance between any two devices or terminating resistors.

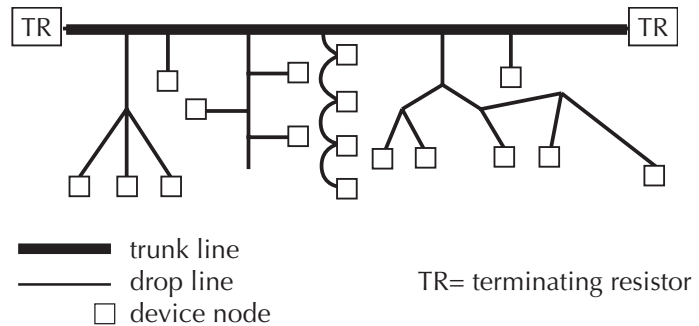

Communication rate	Maximum distance (thick cable)	Maximum distance (thin cable)	Cumulative drop line length
125k bit/s	500m (1640ft)	100m (328ft)	156m (512ft)
250k bit/s	250m (820ft)	100m (328ft)	78m (256ft)
500k bit/s	100m (328ft)	100m (328ft)	39m (128ft)

### Guidelines for Supplying Power

Follow these guidelines to protect your devices and achieve the best results when supplying power to the DeviceNet cable system.

- Use power supplies rated at 24V (±1%).
- Select a power supply that provides sufficient current for all attached devices. (In the U.S. and Canada, be sure to adhere to NEC and CECODE limits respectively.)
- Use a power supply that has its own current limit protection.
- Make sure you derate the supply for temperature using the manufacturer's guidelines.
- Provide fuse protection for each segment of the cable system - any section leading away from a power supply must have protection (can be part of the power tap).
- Use a Schottky diode coupled to the V+ line with a power supply (can be part of the power tap if using supplies in parallel).

**Important:** See page 2-16 for details on selecting a power supply.

### Determine the Maximum Cable Distance

If the distance from a trunk line tap to the farthest device connected Cable Distance to it is greater than the distance from the tap to the nearest terminating resistor, then the drop line length must be included as part of the cable length.



Communication rate	Maximum cable distance (thick cable)	Maximum cable distance (thin cable)
125k bit/s	500m (1640ft)	100m (328ft)
250k bit/s	250m (820ft)	100m (328ft)
500k bit/s	100m (328ft)	100m (328ft)

The distance between any two points must not exceed the maximum cable distance allowed for the communication rate used. See the following example.

### Determine the Cumulative Dropline Length

The cumulative drop line length refers to the sum of all drop lines, Drop Line Length thick or thin cable, in the cable system. This sum cannot exceed the maximum cumulative length allowed for the given communication rate used.

Communication rate	Cumulative drop line length
125k bit/s	156m (512ft)
250k bit/s	78m (256ft)
500k bit/s	39m (128ft)

The following example uses four tee taps and two connectorized taps to attach 13 devices to the trunk line. The cumulative drop line length is 42m (139ft) where no node is more than 6m (20ft) from the trunk line tap. This allows you to use a communication rate of 250k bit/s or 125k bit/s.

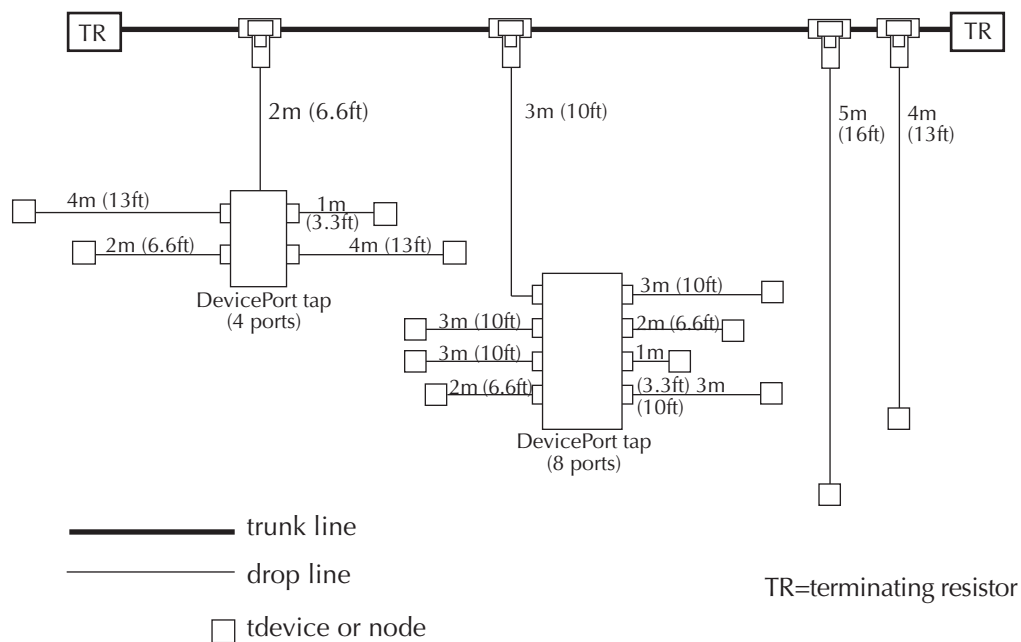



### Power Ratings

The power capabilities of the DeviceNet cable system include:

- power supplies rated at 24V dc (see page 1-16 for specifications)
- power supply taps that optionally:
  - prevent back-feeding of current between multiple power supplies if supplied with Schottky diode
  - can provide overcurrent protection for the trunk line
- thick cable trunk line rating of 8A  
(Check your national and local codes for additional information. In the United States and Canada, the DeviceNet cable system must be installed as a Class 2 circuit. This requires limiting the current to 4A. The rating of the power conductors themselves is 8A.)

Although the thick cable rating is 8A, the cable system can support a total load of more than 8A. For example, a 16A power supply located somewhere in the middle of the cable system can supply 8A to both sides of the power tap. Very large loads can be handled as long as no more than 8A is drawn through any single segment of the trunk line. Due to cable resistance, voltage drops may limit your application to less. Details are provided later in this chapter.

- thin cable trunk line rating of 3A  
Resistance losses may limit your application to less. Details are provided later in this chapter.
- drop line rating of 3A depending on the drop line length. The maximum current decreases as the drop line length increases. This applies to both thick and thin cable.

Drop line length	Allowable current
1.5m (5ft)	3A
2m (6.6ft)	2A
3m (10ft)	1.5A
4.5m (15ft)	1A
6m (20ft)	0.75A

You may also determine the maximum current in amps (I) by using:

$$I = 15/L \quad L = \text{drop line length (ft)}$$

$$I = 4.57/L \quad L = \text{drop line length (m)}$$

The maximum allowable current applies to the sum of currents for all nodes on the drop line. As shown in the example on page 2-3, the drop line length refers to the maximum cable distance from any node to the trunk line, not the cumulative drop line length.

- high maximum common mode voltage drop on the V- and V+ conductors
  - the voltage difference between any two points on the V- conductor must not exceed the maximum common mode voltage of 5V
- voltage range between V- and V+ at each node within 11 to 25V

### Locating a Power Supply

The DeviceNet cable system allows several options for supplying power. To determine which option meets your needs, consider the distribution of the loads, power supply location, and the number of supplies used. Power supplies must be 24 volts (in the United States and Canada, the power supply must also be Class 2). See page 1-16 for more information.

**Important:** Whenever two or more power supplies are connected to the same segment (no break in V+), a diode must be used at the power tap to prevent back-feeding.

#### If you're using:

1 power supply

#### Location can be:

at the end, in the middle, or anywhere if the total load does not exceed maximum allowable current

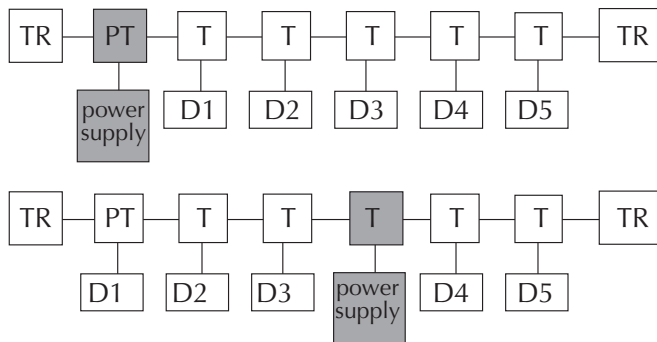

2 power supply

at the ends (diodes required at power taps)

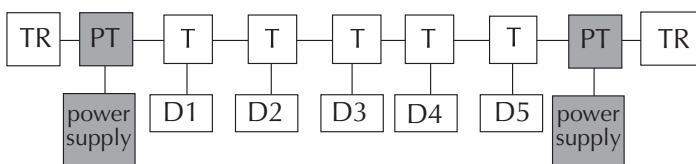

If you're using:

Location can be:

2 power supply (cont.)

next to each other (NEC/CECode current boost configuration)

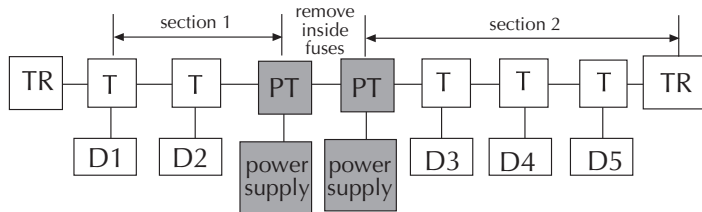

at the end and middle (diodes required at power taps)

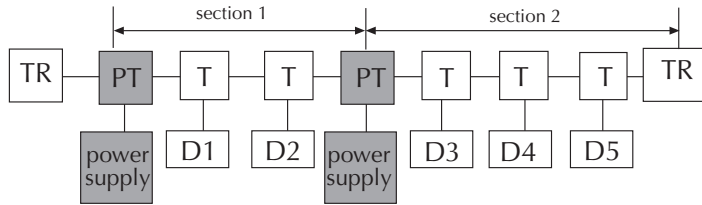

TR= terminating resistor  
PT= power tap

T= tee top  
D= device

## Using the Look-Up Method

To determine if you have adequate power for the devices in your cable system refer to the following examples and figures. You have enough power if the total load does not exceed the value shown by the curve or the table.

In a worse-case scenario, all of the nodes are together at the opposite end of the power supply.

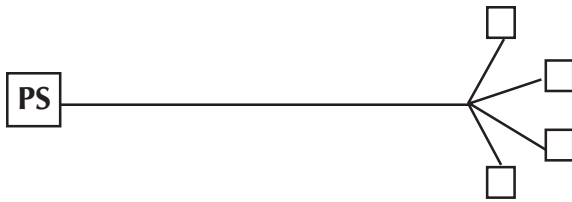

Note: This method may underestimate the capacity of your network by as much as 4 to 1. Use appendix A to do the full calculation method if your supply doesn't fit under the curve.

For this configuration example	See page	Thick cable uses figure	Thin cable uses figure
one power supply (end-connected)	1-9	A	D
one power supply (middle-connected)	1-10	A	D
NEC/CECode current boost configuration	1-12	A	D
two power supplies (end-connected)	1-13	B	*
two power supplies (not end-connected)	1-14	B, C	*

\* Up to 3A can be drawn from a thin cable trunk line if the power supply separation is below 70m.



### Maximum Allowable Current

Find the value next largest to your network using the appropriate figure below to determine the maximum current allowed for the system (approximately).

#### A One Power Supply (End Segment) *Thick Cable*

Note: Assumes all nodes are at the opposite end of the cable from the power supply.

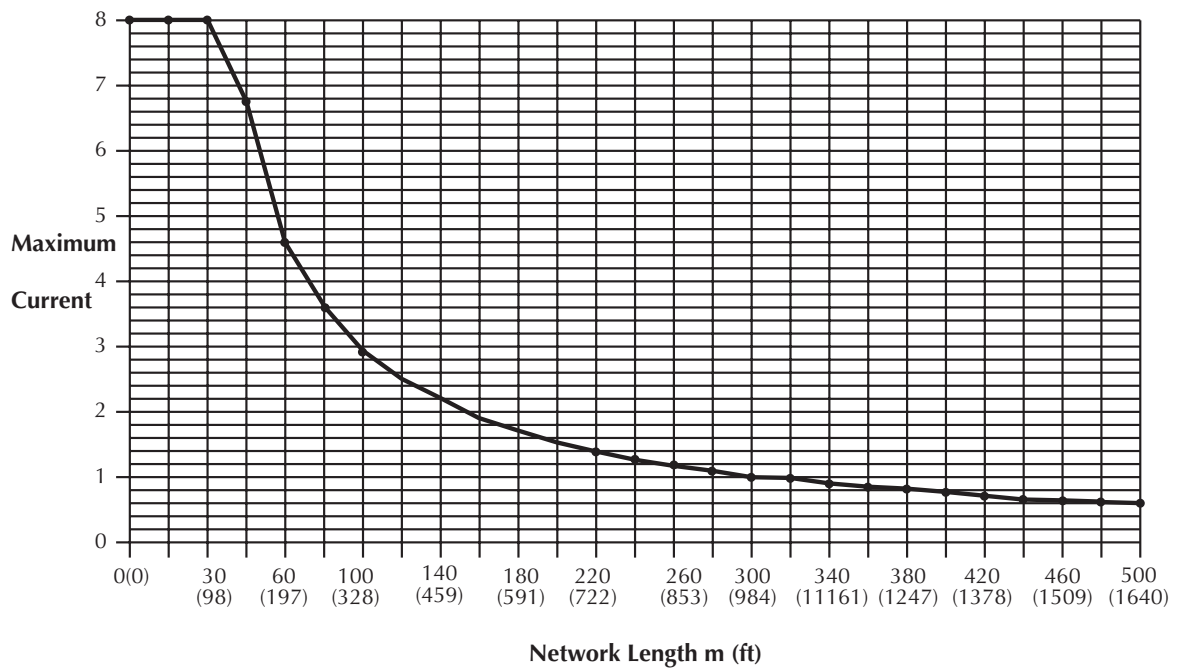

Network Length	Maximum	Network Length	Maximum	Network Length	Maximum
m (ft)	Current (A)	m (ft)	Current (A)	m (ft)	Current (A)
0 (0)	8.00*	160 (525)	1.89	340 (1116)	0.91
20 (66)	8.00*	180 (591)	1.6	360 (1181)	0.86
30 (98)	8.00*	200 (656)	1.53	380 (1247)	0.82
40 (131)	6.53*	220 (722)	1.39	400 (1312)	0.78
60 (197)	4.63*	240 (787)	1.28	420 (1378)	0.74
80 (262)	3.59	260 (853)	1.19	440 (1444)	0.71
100 (328)	2.93	280 (919)	1.10	460 (1509)	0.68
120 (394)	2.47	300 (984)	1.03	480 (1575)	0.65
140 (459)	2.14	320 (1050)	0.97	500 (1640)	0.63
		* Exceeds NEC/CECode 4A limit			

## B Segment Between Two Power Supplies *Thick*

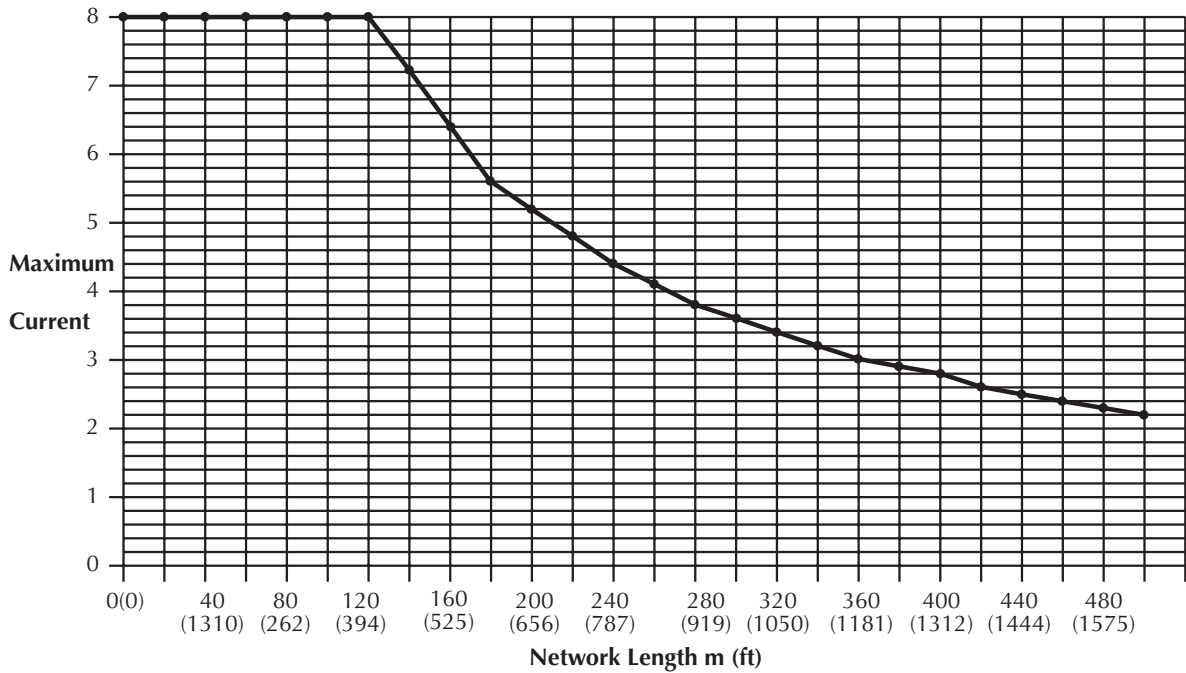

Network Length m (ft)	Maximum Current (A)	Network Length m (ft)	Maximum Current (A)	Network Length m (ft)	Maximum Current (A)
0 (0)	8.00*	180 (591)	5.76*	360 (1181)	3.02
20 (66)	8.00*	200 (656)	5.23*	380 (1247)	2.86
40 (131)	8.00*	220 (722)	4.79*	400 (1312)	2.73
60 (197)	8.00*	240 (787)	4.42*	420 (1378)	2.60
80 (262)	8.00*	260 (853)	4.10*	440 (1444)	2.49
100 (328)	8.00*	280 (919)	3.83	460 (1509)	2.38
120 (394)	8.00*	300 (984)	3.59	480 (1575)	2.29
140 (459)	7.23*	320 (1050)	3.37	500 (1640)	2.20
160 (525)	6.41*	340 (1116)	3.18		

\* Exceeds NEC/CECode 4A limit.



**C End Segment in Two Power Supply System *Thick***

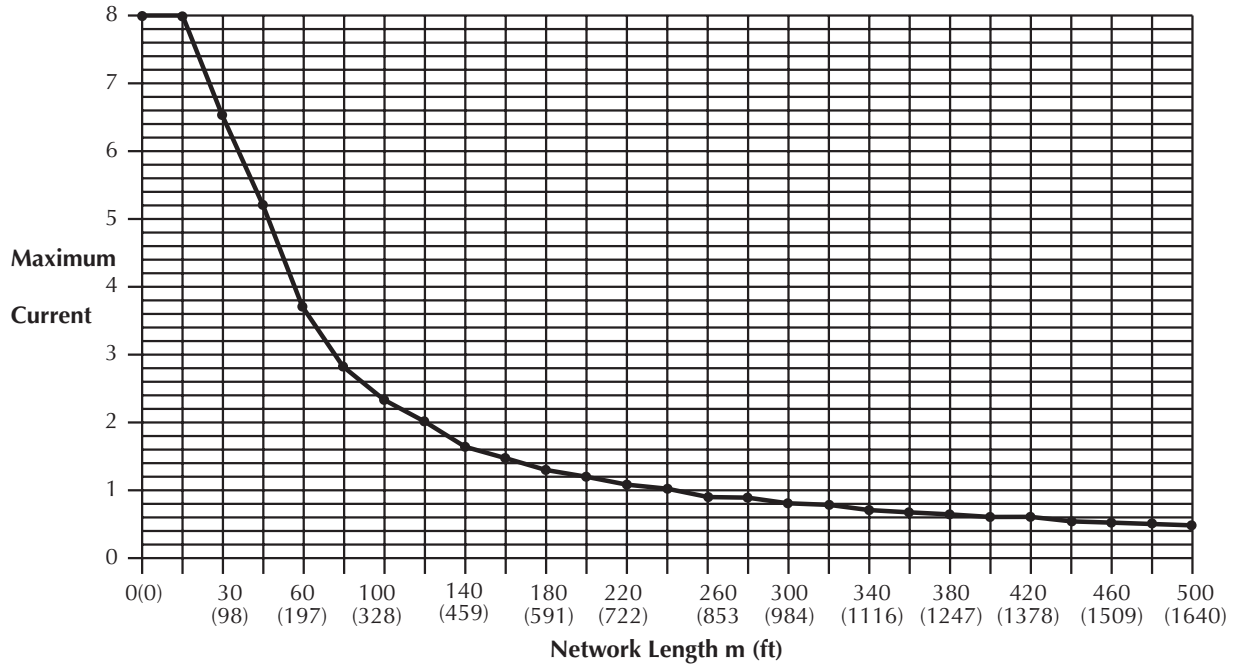

Network Length m (ft)	Maximum Current (A)	Network Length m (ft)	Maximum Current (A)	Network Length m (ft)	Maximum Current (A)
0 (0)	8.00*	160 (525)	1.50	340 (1116)	0.72
20 (66)	8.00*	180 (591)	1.34	360 (1181)	0.69
30 (98)	6.52*	200 (656)	1.21	380 (1247)	0.65
40 (131)	5.18*	220 (722)	1.10	400 (1312)	0.62
60 (197)	3.68	240 (787)	1.02	420 (1378)	0.59
80 (262)	2.85	260 (853)	0.94	440 (1444)	0.56
100 (328)	2.32	280 (919)	0.88	460 (1509)	0.54
120 (394)	1.96	300 (984)	0.82	480 (1575)	0.52
140 (459)	1.70	320 (1050)	0.77	500 (1640)	0.50

\* Exceeds NEC/CECode 4A limit.

## D One Power Supply (End Segment) *thin*

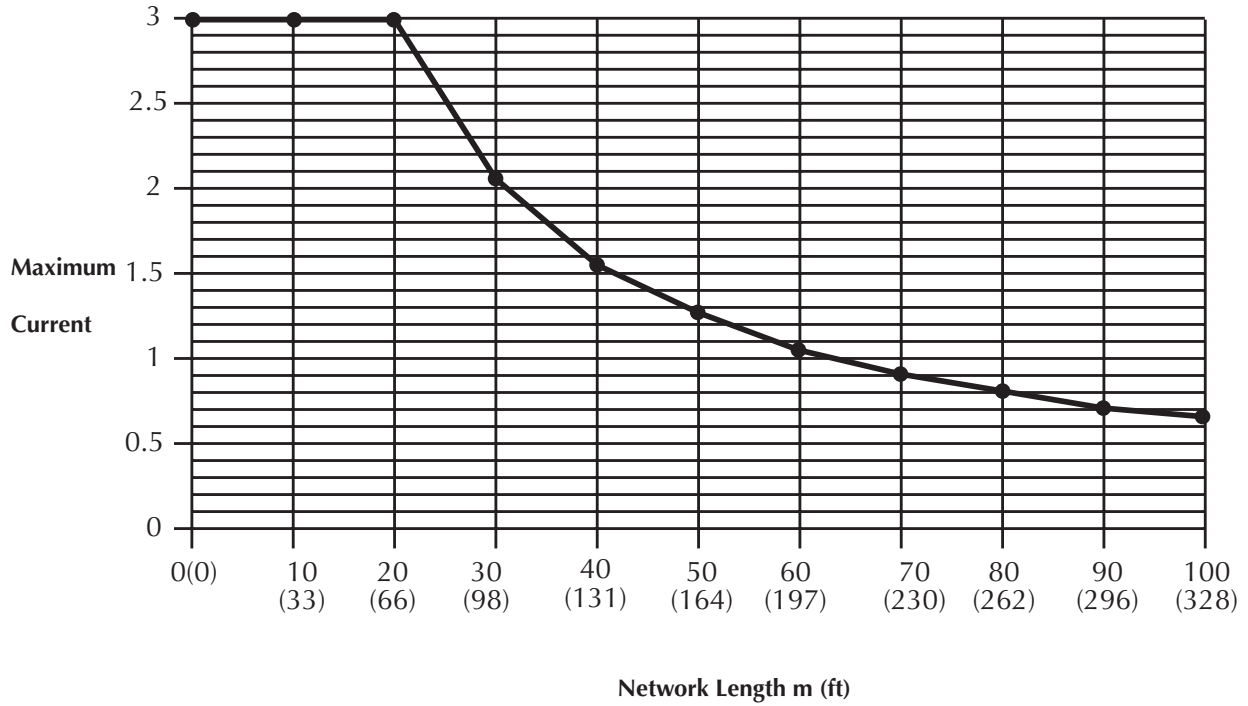

Network Length m (ft)	Maximum Current (A)	Network Length m (ft)	Maximum Current (A)
0 (0)	3.00	60 (197)	1.06
10 (33)	3.00	70 (230)	0.90
20 (66)	3.00	80 (262)	0.80
30 (98)	2.05	90 (295)	0.71
40 (131)	1.57	100 (328)	0.64
50 (164)	1.26		

## One Power Supply (End-Connected)

The following example uses the look-up method to determine the configuration for one end-connected power supply. One end-connected power supply provides as much as 8A

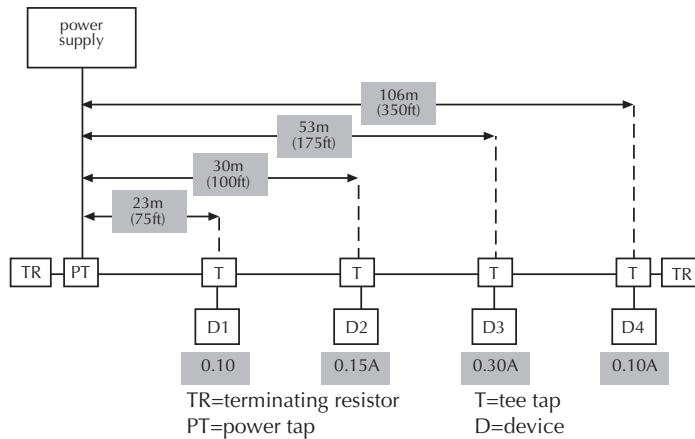

near the power supply.

- Determine the total length of the network.
- Add each devices current together to find the total current.  
**Important:** Make sure that the required power is less than the rating of the power supply. You may need to derate the supply if it is in an enclosure.
- Find the value next largest to the network length using figure A on page 2-8 to determine the maximum current allowed for the system (approximately).

106m

$$0.10 + 0.15 + 0.30 + 0.10 = 0.65A$$

120m (2.47A)

Results



Since the total current does not exceed the maximum allowable current, the system will operate properly ( $0.65A \leq 2.47A$ ).

**Note:** If your application doesn't fit "under the curve", you may either:

- do the full-calculation method described in Appendix A
- move the power supply to somewhere in the middle of the cable system and reevaluate per the following section

### One Power Supply (Middle-Connected)

The following example uses the look-up method to determine the configuration for one middle-connected power supply. One middle-connected power supply provides the maximum current capability for a single supply.

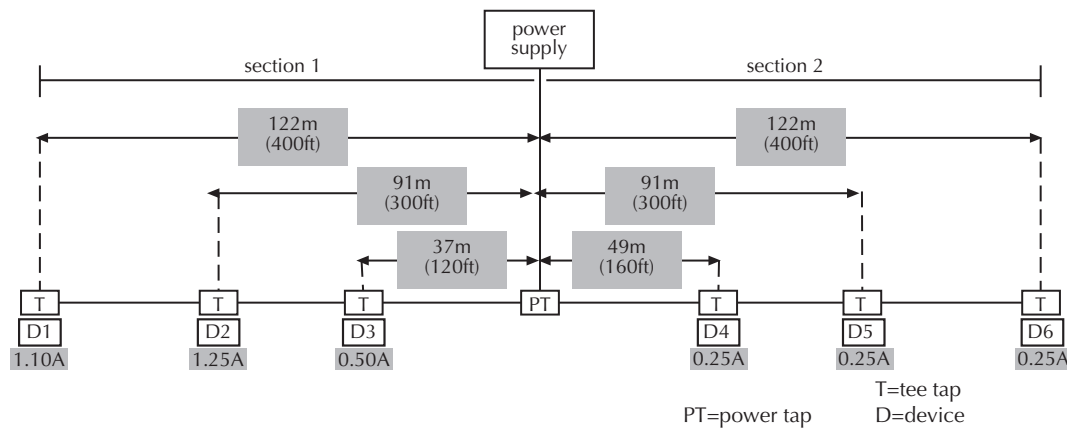

1. Add each devices current together in section 1.
2. Add each devices current together in section 2.

$$1.10 + 1.25 + 0.50 = 2.85A$$

$$0.25 + 0.25 + 0.25 = 0.75 A$$

3. Find the value next largest to each sections length using figure A on page 2-8 to determine the maximum current allowed for each section (approximately).

**Section 1** ⚡ 140m (2.14A)  
**Section 2** ⚡ 140m (2.14A)

**Important:** Section 1 + Section 2 < 3.6A. This is ≤ 4 A NEC/CECode compliance.

Results



Section 1 is overloaded because the total current exceeds the maximum current ( $2.85A \geq 2.14A$ ).  
 Section 2 is operational since the total current does not exceed the maximum current ( $0.75A \leq 2.14A$ ).

Balance the system by moving the power supply toward the overloaded section (section 1). Then recalculate each section.

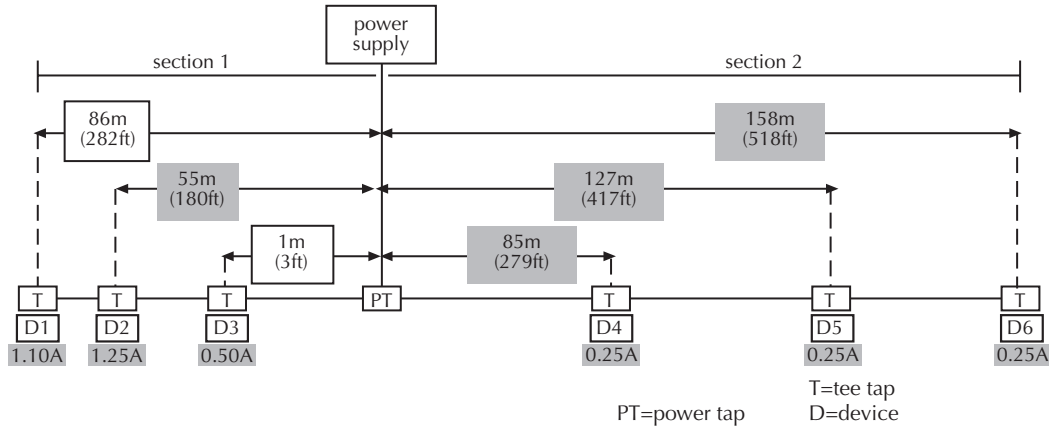

1. Add each devices current together in section 1.
2. Add each devices current together in section 2.
3. Find the value next largest to each sections length using figure A on page 2-8 to determine the maximum current allowed for each section (approximately).

$$1.10 + 1.25 + 0.50 = 2.85 \text{ A}$$

$$0.25 + 0.25 + 0.25 = 0.75 \text{ A}$$

Section 1 ⚡ 100m (2.93A)  
Section 2 ⚡ 160m (1.89A)

**Important:** Section 1 + Section 2 , 3.6A. This is  $\leq 4\text{A}$  for NEC/CECode compliance. **However, if due to derating of the power supply you had to use over a 4A power supply, Would exceed the NEC/CEode maximum allowable current.**

Results

Section 1 is operational since the total current does not exceed the maximum current ( $2.85\text{A} \leq 2.93\text{A}$ ).  
Section 2 is operational since the total current does not exceed the maximum current ( $0.75\text{A} \leq 1.89\text{A}$ ).

### Adjusting the Configuration

Some ways to make your system operational include:

- move the power supply in the direction of the overloaded section
- move higher current loads as close to the supply as possible
- move devices from the overloaded section to the another section
- shorten the overall length of the cable system
- perform the full-calculation method for the segment described in Appendix A for the non-operational section
- add a second power supply to the cable system (do this as a last resort) as shown in the following three examples

## NEC/CECode Current Boost Configuration

If the national or local codes limit the maximum rating of a power supply, the following configuration can be used to replace a single, higher current power supply.

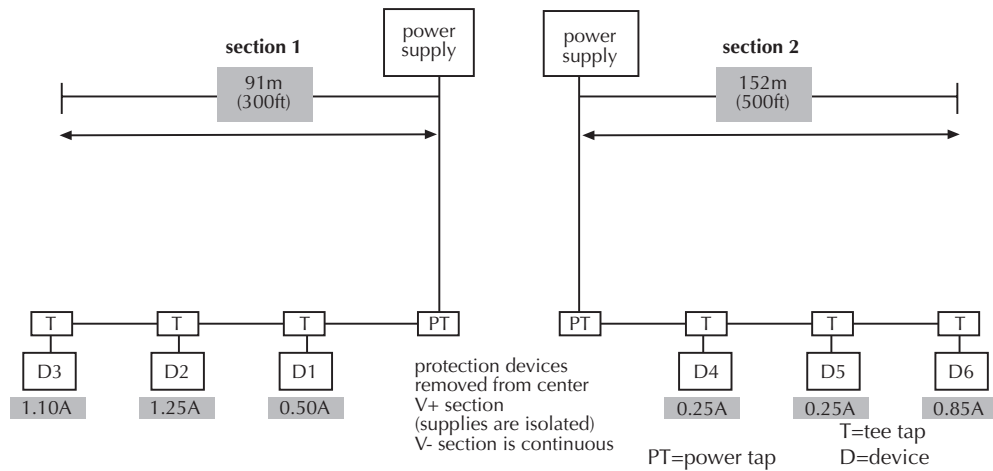

This configuration effectively doubles the available current. It has the following characteristics:

- no loads are allowed between the power taps
- fuses between the two power taps must be removed to segment the V+ conductor in the trunk line between the taps - Also cut V+ (red) flush with cable jacket.

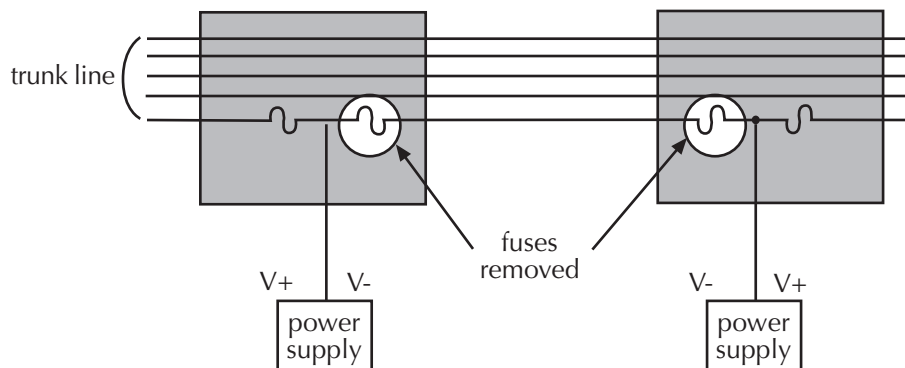

power tap modifications

- essentially two independent segments, each of which is a "one power supply end-connected system" - use figure A on page 2-8 for each segment
- each power supply can be rated up to 4A and still meet NEC/CECode Class 2 current restrictions

### Two Power Supplies (End-Connected)

The following example uses the look-up method to determine the configuration for two end-connected power supplies. Diodes must be used at the power taps to prevent back-feeding of the power supplies. Check your national and local codes for any restrictions on the use of parallel power supplies. The NEC/CECode requires that the power supplies must be listed for parallel operation.

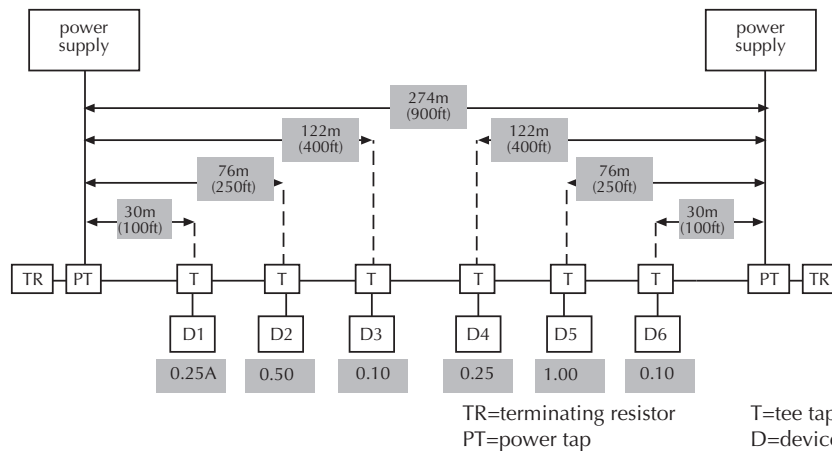

1. Determine the total length of the network.
2. Add each device's current together to find the total current.
3. Find the value next largest to each section's length using figure B on page 2-9 to determine the maximum current allowed for the system (approximately).

274m
0.25 + 0.50 + 0.10 +
0.25 + 1.00 + 0.10 = 2.20A
280m (3.83A)

Results



Since the total current does not exceed the maximum current, the system will operate properly (2.20A < 3.83A).

Note: Schottky diodes need to be placed in series with each power supply to keep back-feeding of current to power supplies. The total capabilities of both supplies must be less than or equal to 4A in North American and supplies must be listed for parallel operation.

### Two Power Supplies (Not End-Connected)

The following example uses the look-up method to determine the configuration for two power supplies that are not end-connected. This configuration provides the most power to the cable system. Diodes must be used at the power taps to prevent back-feeding of the power supplies. Check your national and local codes for any restrictions on the use of parallel power supplies.

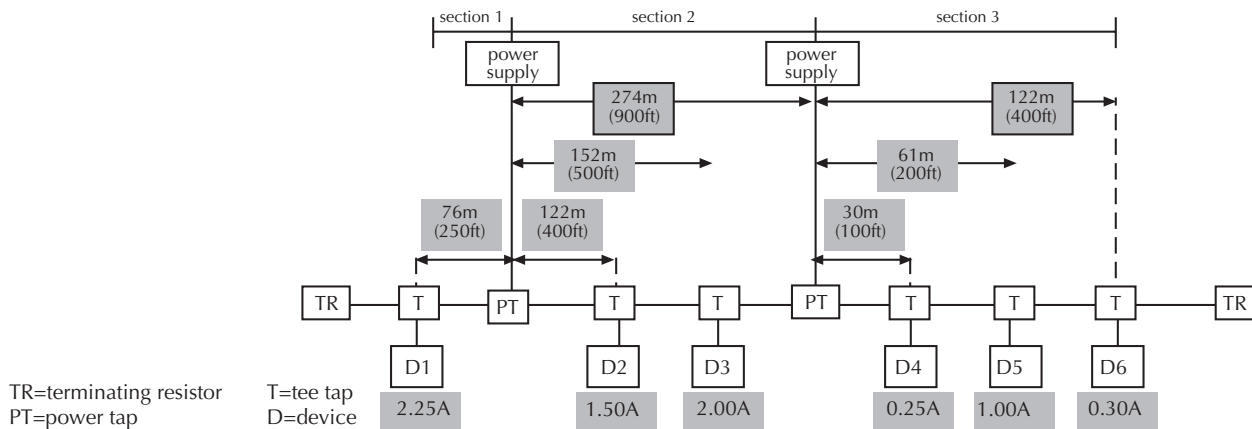

1. Determine the trunk line length of one end section (for this example we will use section 3).
2. Add each device's current together in section 3.
3. Find the value next largest to the length of section 3 using figure C on page 2-10 to determine the maximum current allowed (approximately).

122m

$$0.25 + 1.00 + 0.30 = 1.55A$$

$$140m (1.70A)$$

**Important:** If the total current in the section exceeds the maximum allowable current, move the power supply closer to the end and repeat steps 1-3 until the total current in the section is less than the maximum allowable current.

Results



Since the total current does not exceed the maximum current, section 3 will operate properly ( $1.55A \leq 1.70A$ ).  
Loading is 91% ( $1.55/1.70$ ).

4. Determine the trunk line length of the other end section (section 1).
5. Add each devices current together in section 1.
6. Find the value next largest to the length of section 1 using figure C on page 2-10 to determine the maximum current allowed (approximately).

76m

2.25A

80m (2.85A)

**Important:** If the total current in the section exceeds the maximum current, move the power supply closer to the end and repeat steps 4-6 until the total current in the section is less than the maximum allowable current.

Results



Since the total current does not exceed the maximum current, section 1 will operate properly (2.25A ≤ 2.85A).  
Loading is 80% (2.25/2.85).

7. Determine the length of the middle section (section 2).
8. Add each devices current together in section 2.
9. Find the value next largest to the length of section 2 using figure B on page 2-9 to determine the maximum current allowed (approximately).

275m

1.50 + 2.00 = 3.50A

280m (3.83A)

**Important:** If the total current in the section exceeds the maximum current, move the power supplies closer together and repeat steps 7-9 until the total current in the section is less than the maximum allowable current.

Results



Since the total current does not exceed the maximum allowable current, section 2 will operate properly (3.50A ≤ 3.83A).  
Loading is 91% (3.50/3.83).

If the middle section is still overloaded after moving the power supplies closer together, add a third power supply. Then recalculate each segment.

**Important:** Section 1 + Section 2 + Section 3 = 7.3A. This is ≥ 4A and does not comply with the NEC/CECode.

**Note:** To determine spare capacity for future expansion, subtract the actual current from the maximum allowable current. To determine the percentage loading for each segment, divide the maximum allowable current into the actual current.

Segment	Maximum Current - Actual Current	=	Spare Capacity	% Loading/Segment
1	2.85A - 2.25A	=	0.60A	80% (2.25A/2.85A)
2	3.83A - 3.50A	=	0.33A	91% (3.50A/3.83A)
3	1.70A - 1.55A	=	0.15A	91% (1.55A/1.70A)



## Choosing a Power Supply

The total of all the following factors must not exceed 3.25% of the nominal 24V needed for a DeviceNet cable system.

- initial power supply setting – 1.00%
- line regulation – 0.30%
- temperature drift – 0.60% (total)
- time drift – 1.05%
- load regulation – 0.30%

Use a power supply that has its own current limit protection.

**Important:** The DC output of all supplies must be isolated from the ac side of the power supply and the power supply case.

If a single power supply is used, add up the current requirements of all devices drawing power from the network. This is the minimum name-plate current rating that the power supply should have.

Your national and local codes may not permit the full use of the power system capacity. For example, **in the United States and Canada, the power supplies used must be Class 2 listed per the NEC and CECODE, respectively.** The total current available to a trunk line segment must not exceed 4A. In addition, if multiple power supplies are used, they must be listed for parallel applications.

### Sizing a Power Supply

Follow the steps below to determine the minimum continuous current rating of a power supply servicing a common section. Repeat these steps for each power supply.

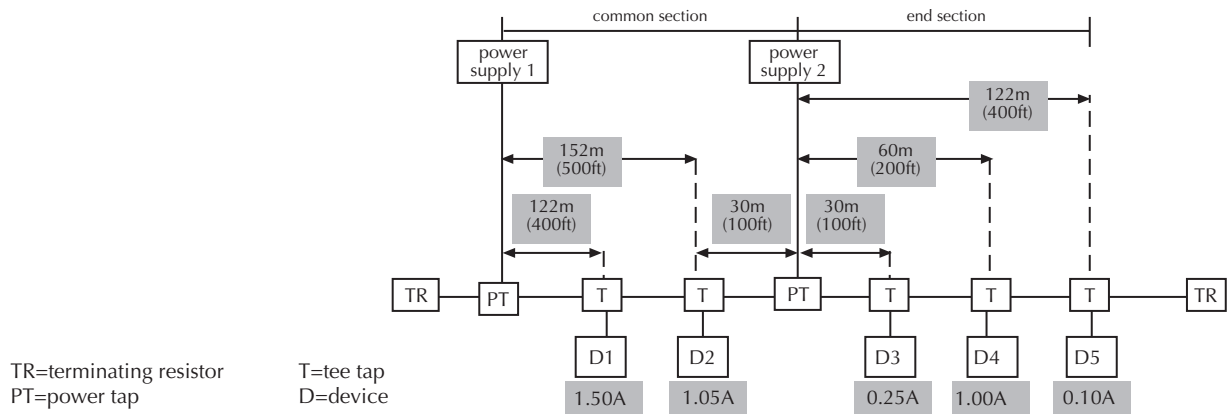

#### Power Supply 1

$$1.50 + 1.05 = 2.55A$$

1. Add each device's current together in the common section that are more than 20m (65ft) from the other power supply (in most cases, the current for devices in the middle of a common section are included in both power supply capacities).

**Results** 2.55A is the minimum name-plate current rating that power supply 1 should have. Remember to consider any temperature or environmental derating recommended by the manufacturer.

**Important:** This derating factor typically does not apply when considering maximum short circuit current allowed by your national and local codes.

#### Power Supply 2

$$0.25 + 1.00 + 0.10 = 1.35$$

1. Add each device's current together in the end section.
2. Add each device's current together in the common section that are more than 20m (65ft) from the other power supply. (In most cases, the current for devices in the middle of a common section are included in both power supply capacities).
3. Add the results from step 1 and 2.

$$1.50 + 1.05 = 2.55A$$

$$1.35 + 2.55 = 3.90A$$

**Results** 3.90A is the minimum name-plate current rating that power supply 2 should have. Remember to consider any temperature or environmental derating recommended by the manufacturer.

**Important:** In the United States and Canada, this configuration would not be allowed as the total current from power supply 1 and power supply 2 is  $2.55 + 3.90 = 6.45A$ . This is greater than the 4A maximum current allowed.

### Grounding the Cable System

You must ground your DeviceNet cable system at only one location.

**Important:** If you use more than one power tap, only one of them should be attached to an earth ground

Ground the V - conductor, shield, and drain wire at only one place - at the power tap that is closet to the physical center of the network (if possible) to maximize the effect of outside noise.

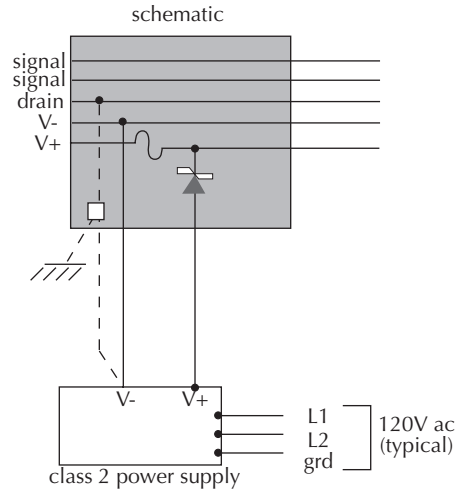

#### Description

**recommended**

#### Grounding

near center of cable system, attached to power tap and earth ground

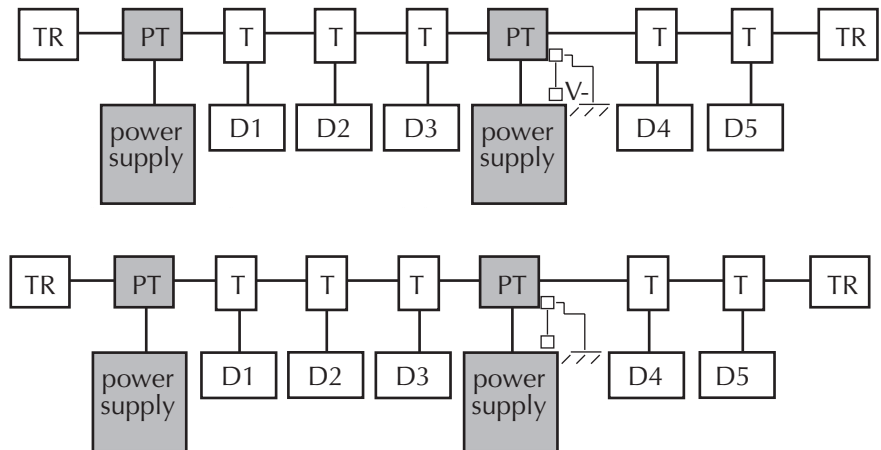

TR=terminating resistor  
PT=power tap  
T=tee tap  
D=device

To ground the network:

- Connect the network shield and drain wire to an earth or building ground using a 0.25mm (1in) copper braid or a #8 AWG wire up to 3m (10ft) maximum in length
- Use the same ground for the V- conductor of the cable system and the dc ground of the power supply. If possible, this should be at the power tap.

**Important:** For a non-isolated device, make sure that additional network grounding does not occur when mounting the device or through external connections to the device. Check the device manufacturer's instructions carefully for grounding information.



## Termination the Cable System

Install terminating resistors at the end of the trunk line.

**Important:** Do not put the terminating resistor on a node. Doing so risks network failure if you remove the node. The resistor must be at the end of the trunk line. Use a(n):

- sealed terminating resistor – when the trunk line ends at a tee tap
- open-style terminating resistor – when the trunk line ends in an enclosure or a junction box tap

Refer to page 3-7 for details.

## What's Next

Now that you have determined the layout of your cable system and how to supply enough power to the devices, read the next chapter to learn how to connect devices, attach cables to connectors and taps, and ground and terminate the cable system.



## Installing a DeviceNet Cable System

### What's in This Chapter

To complete the installation of your DeviceNet cable system, follow the instructions in this chapter.

For information on	See page
installing a DeviceNet Cable System	3-1
preparing cables	3-2
using pinouts	3-3
connecting drop lines	3-4
connecting power supplies	3-5
grounding the cable system	3-6
terminating the system	3-7
applying power	3-8

### Installing a DeviceNet Cable System

For your safety and the successful installation of your DeviceNet network, follow these guidelines.

- **Cable placement** – When determining placement of the trunk lines and drop lines, consider:
  - **cable rating** – as the cable rating is 300V, do not put a cable in a cable tray or conduit that contains higher voltage cables unless you can physically isolate them.
  - **data signaling** – both trunk and drop lines carry data and should be kept at least 0.76mm (3in) from power cables. Put the cable in a separate conduit or cable tray or isolate it from other cables in a cable tray.
- **Codes** – Follow local codes and the standards (such as NEC and CECODE) where applicable.
- **Wiring** – Do not install wires on an active network, if possible.
- **Voltage testing** – After installation, make sure that the minimum voltage and maximum voltage drops at each node meet the system requirements.

### Preparing Cables

In Chapter 2, you determined the required lengths of trunk line and drop line segments for your network. To cut these segments, from reels of thick cable and thin cable, use a sharp cable cutter and provide sufficient length in each segment to reduce tension at the connector.

**Important:** Follow the manufacturer's instructions for stripping, crimping, and/or tightening.

Select an end of the thick cable segment that has been cleanly cut. The positions of the color-coded conductors should match the positions at the face of the connector:

### Using Pinouts

These pinouts are available with the DeviceNet network.

#### Micro-Style Connectors

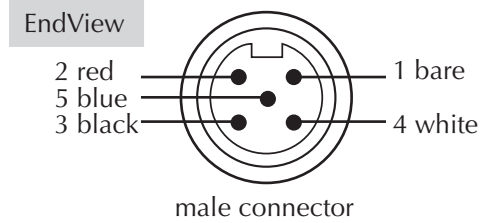

Notice that the pinout for the male connector is the opposite of the female connector

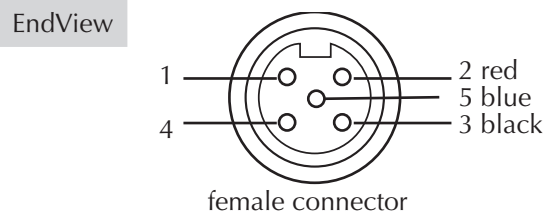

#### Mini-Style Connectors

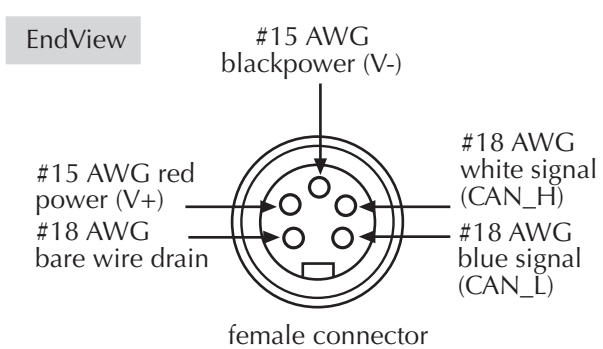
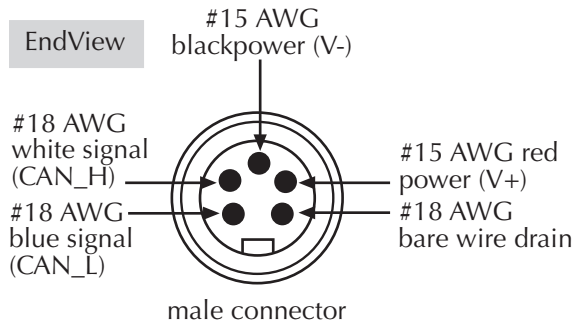

#### 5-pin Linear Plugs

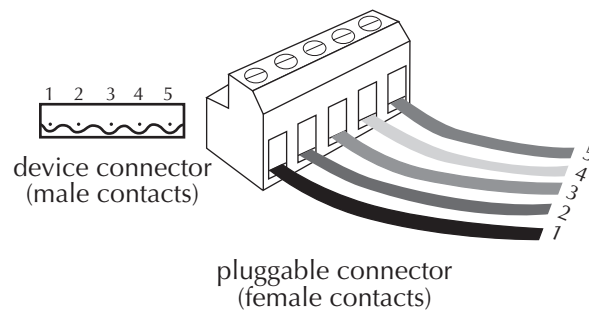
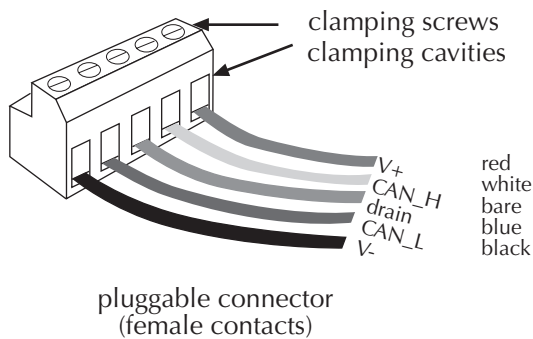



## Connecting Drop Lines

Drop lines, made up of thick or thin cable, connect devices to taps. Connections at the device can be:

- open-style
  - pluggable screw connectors
  - hard-wired screw terminals
  - soldered
- sealed-style
  - mini quick-disconnect connectors
  - micro quick-disconnect connectors

**Important:** Connect drop lines when the cable system is inactive. If you must connect to an active cable system, make all other connections before the connection to the trunk line.

**ATTENTION:** Although it is possible to make a screw-terminal connection while the cable network is active, you should avoid this if at all possible.

To connect drop lines:

1. Attach contacts as described earlier in this section.
2. Connect the cable to the device.
3. Make any intermediate connections.
4. Make the connection to the trunk line last.

**Important:** Follow the wiring diagrams for each connection, and make sure you do not exceed the maximum allowable length from the device connection to the trunk connection.



## Connecting Power Supplies

To supply power you will need to install and ground the power supplies as well as connect all power taps.

If you haven't determined power supply placement, see page 2-5.

To install a power supply:

**Important:** Make sure the ac power source remains off during installation.

1. Mount the power supply securely allowing for proper ventilation, connection to the ac power source, and protection from environmental conditions according to the specifications for the supply.

2. Connect the power supply using:

- a cable that has one pair of 12 AWG conductors or the equivalent or two pairs of 15 AWG conductor
  - a maximum cable length of 3m (10ft) to the power tap
  - the manufacturer's recommendations for connecting the cable to the supply
- You must ground your DeviceNet cable system at only one location, preferably near the physical center of the network using a power tap.



## Grounding the Cable System

You must ground your DeviceNet cable system at only one location, preferably near the physical center of the network using power tap.

**Important:** Do not put a terminating resistor on a node. Doing so risks network failure if you remove the node. The resistor must be at the end of the trunk line.

- The shield of the cable system and the V- and ground conductor of the power supply should be grounded at the same location.
- Only one location on the cable system should be grounded. Do not connect the grounding terminals of additional power taps or additional power supplies to an earth ground.
- For a non-isolated physical layer device, make sure that additional grounding does not occur due to mounting of the device or external connections to the device.
- Check each manufacturer's product instructions carefully for device grounding information.
- Follow the manufacturer's guidelines for installing and derating the power supply, including how to:
  - wire, fuse, and ground the ac side of the supply
  - mount the supply

To ground the cable system:

1. Connect the network shield and drain wire to an earth or building ground using a 2.5mm (1in) copper braid or an 8 AWG wire up to 3m (10ft).
2. Use the same ground for the V- conductor of the cable system and the ground of the power supply. If possible, this should be at the power tap.

## Terminating the Cable System

To function properly, the cable system must have terminating resistors at the ends of the trunk line.

**Important:** Do not put a terminating resistor on a node. Doing so risks network failure if you remove the node. The resistor must be at the end of the trunk line.

These terminating resistors provide connection to taps and the trunk line.

- sealed-style terminating resistors – male or female connections in mini-style or micro-style attach to:
  - trunk line ends
  - power taps
  - tee taps
  - connectorized taps

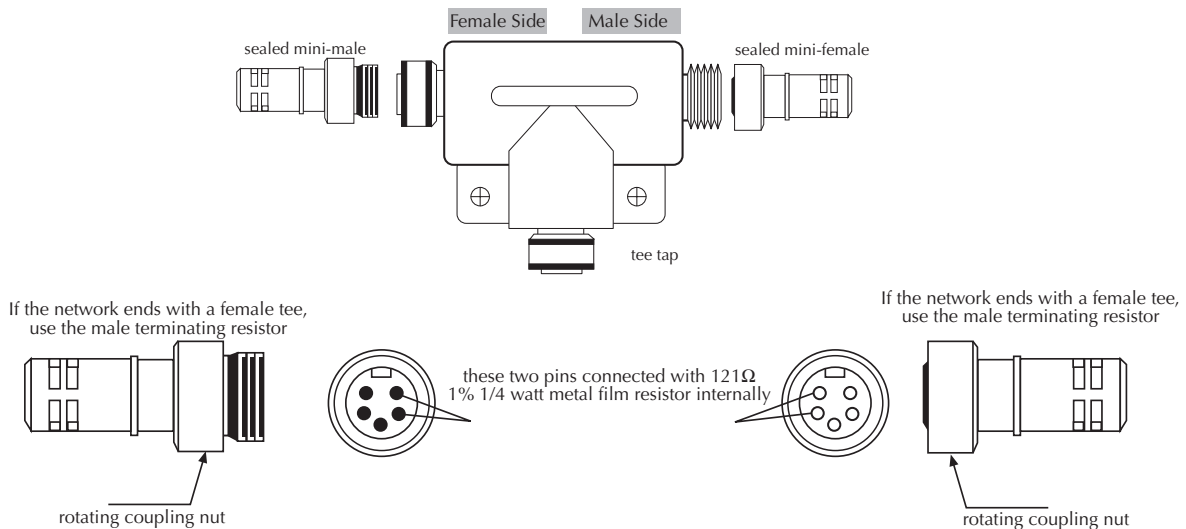

- open-style terminating resistors – 121W, 1%, 1/4W resistors or larger connecting the CAN\_H and CAN\_L conductors in mini-style or micro-style attach to:
  - junction box taps
  - open-style tee taps
  - trunk lines using terminator blocks
  - open-style power taps

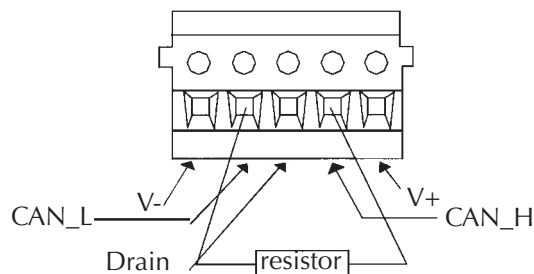



*DeviceNet*<sup>™</sup>

Installing a DeviceNet Cable System

## Apply Power

Apply power only after you have:

- made all connections
- installed terminating resistors
- connected devices



# *DeviceNet*<sup>™</sup>

Installing a DeviceNet Cable System



## Full Calculation Method

### What's in This Appendix

Use the full calculation method if your initial evaluation in Chapter 2 indicates that one section is overloaded or if the requirements of your configuration cannot be met by using the look-up method.

For information on	See page
supplying power	A-1
adjusting the configuration	A-1
using the equation	A-2

**Important:** Before constructing the cable system, repeat all calculations to avoid errors.

### Supplying Power

Follow these guidelines to protect your devices and achieve the best results when supplying power to the DeviceNet cable system.

- Use power supplies rated at 24V ( $\pm 1\%$ ).
- Select a power supply that provides sufficient current for all attached devices.
- Make sure you derate the power tap and the power supply for expected temperature using the manufacturer's guidelines.
- Provide fuse protection for each segment of the cable system - any section leading away from a power supply must have protection unless the power supply is inherently limiting to less than the cable rating.
- Use a Schottky diode coupled to the V+ line with a power supply (when power supplies are used in parallel, can be part of the power tap).
- Use a power supply that has its own current limit protection.

### Adjusting the Configuration

When the sections have a voltage drop less than 4.65V, your configuration will operate properly. Ideally, the voltage drops for each section should be within 10% of each other. If one section has a substantially greater voltage drop than the other, you should attempt to balance the load of the cable system by moving the power supply or devices.

Some ways to make your system operational include:

- shorten the overall length of the cable system.
- move the power supply in the direction of the overloaded section.
- move devices from the overloaded section to the another section.
- move higher current loads as close to the supply as possible.
- add a second power supply to the cable system.
- break the network into two separate networks to reduce the number of devices on each.



### Using the Equation

A supply that is not end connected creates two sections of truck line. Evaluate each independently

$$\text{SUM } \{[(L_n \times R_c) + (N_t \times (0.005))] \times I_n\} \leq 4.65V$$

Term	Definition	Term	Definition
$L_n$	<p><math>L</math> = The distance (m or ft) between the device and the power supply, excluding the drop line distance.</p> <p><math>n</math> = The number of a device being evaluated, starting with 1 for the device closest to the power supply and increasing by 1 for the next device.</p> <p>The equation sums the calculated drop for each device and compares it to 4.65V.</p>	(0.005)	The nominal-contact resistance used for every connection to the trunk line.
$R_c$	<p>Thick cable</p> <p>Metric 0.015 (<math>\Omega</math>/m)</p> <p>English 0.0045 (<math>\Omega</math>/ft)</p> <p>Thin cable</p> <p>Metric 0.069 (<math>\Omega</math>/m)</p> <p>English 0.021 (<math>\Omega</math>/ft)</p>	$I_n$	<p><math>I</math> = The current drawn from the cable system by the device. For currents within 90% of the maximum, use the nominal device current. Otherwise, use the maximum rated current of the device.</p> <p>For junction box taps or connectorized taps, sum the current of all the attached devices, and count the tap as one tap.</p> <p><math>n</math> = The number of a device being evaluated, starting with 1 for the device closest to the power supply and increasing by 1 for the next device.</p>
$N_t$	<p>The number of taps between the device being evaluated and the power supply. For example:</p> <ul style="list-style-type: none"> <li>· when a device is the first one closest to the power supply, this number is 1</li> <li>· when a device has one device between it and the power supply, this number is 2</li> <li>· when 10 devices exist between the evaluated device and the power supply, this number is 11.</li> </ul> <p>For devices attached to a junction box tap or connectorized tap, treat the tap as one tap. The currents for all devices attached to one of these taps should be summed and used with the equation only once.</p>	4.65V	The maximum voltage drop allowed on the DeviceNet trunk line. This is the total cable system voltage drop of 5.00V minus 0.35V reserved for drop line voltage drop.

### One Power Supply (End-Connected)

#### Example of Thick Cable

The following example uses the full calculation method to determine the configuration for one end-connected power supply on a thick cable trunk line.

- Device 1 and Device 2 cause the same voltage drop but Device 2 is twice as far from the power supply and draws half as much current.
- Device 4 draws the least amount of current but it is furthest from the power supply and causes the greatest incremental voltage drop

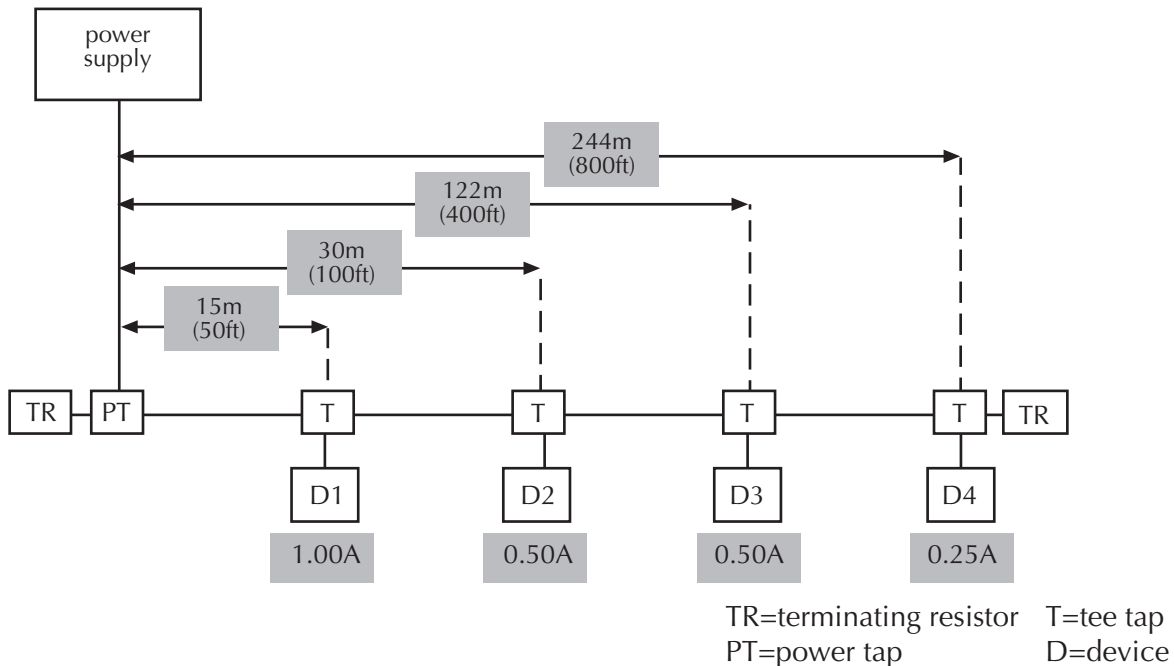

1. Find the voltages for each device using the equation for thick cable.

$$SUM \{ [(Ln \times (0.0045)) + (Nt \times (0.005))] \times In \} \leq 4.65V.$$

**D1**

A.  $[(50 \times (0.0045)) + (1 \times (0.005))] \times 1.00 = 0.23V$

**D2**

B.  $[(100 \times (0.0045)) + (2 \times (0.005))] \times 0.50 = 0.23V$

**D3**

C.  $[(400 \times (0.0045)) + (3 \times (0.005))] \times 0.50 = 0.91V$

**D4**

D.  $[(800 \times (0.0045)) + (4 \times (0.005))] \times 0.25 = 0.91V$

2. Add each devices voltage together to find the total voltage.  
 $0.23V + 0.23V + 0.91V + 0.91V = \mathbf{2.28V}$

Results  Since the total voltage does not exceed 4.65V, the system will operate properly ( $2.28V \leq 4.65V$ ).

The percent loading is found by dividing the total voltage by 4.65V.  
 $\%Loading = 2.28/4.65 = \mathbf{49\%}$

### One Power Supply (Middle-Connected)

#### Example of Thick Cable

This example is used to check loading on both sides of a middle-connected supply on a thick cable trunk line. Keep the loads, especially the higher ones, close to the power supply. If the device location is fixed, put the power supply in the center of the highest current concentration.

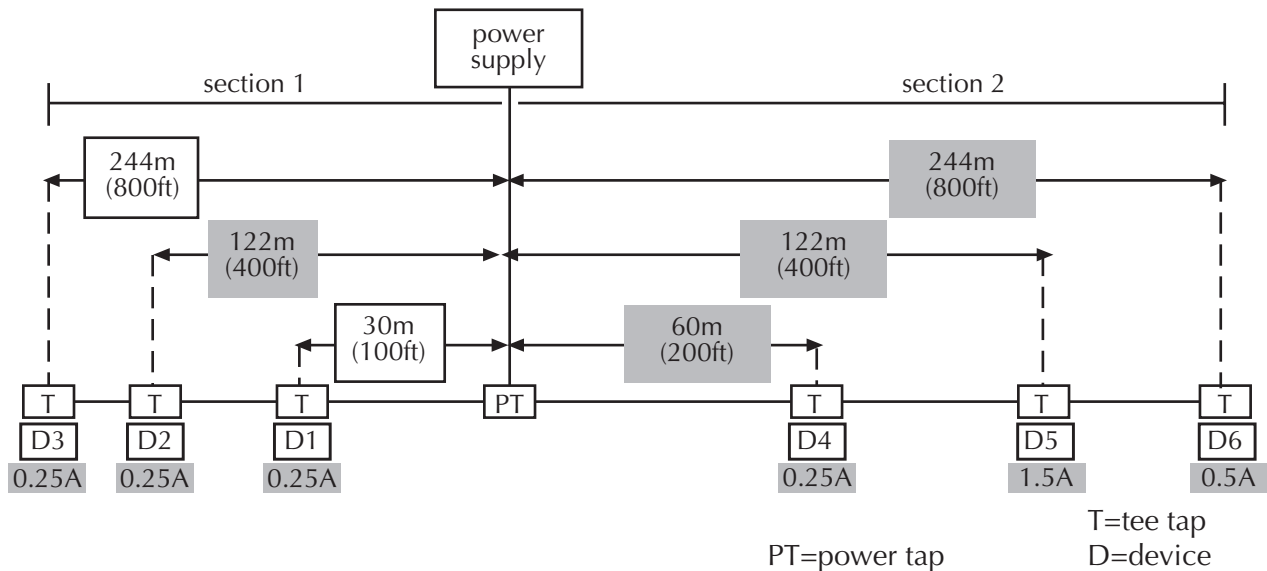

tration.

According to the look-up method, section 1 is operational while section 2 is overloaded.

Value of	Section 1	Section 2
total maximum current	1.25A (approximately)	1.25A (approximately)
total current required	0.75A	2.25A

- Find the voltages for each device in section 1 using the equation for thick cable.

$$SUM \{[(L_n \times (0.0045)) + (N_t \times (0.005))] \times I_n\} \leq 4.65V.$$

**D1**

A.  $[(100 \times (0.0045)) + (1 \times (0.005))] \times 0.25 = 0.12V$

**D2**

B.  $[(400 \times (0.0045)) + (2 \times (0.005))] \times 0.25 = 0.45V$

**D3**

C.  $[(800 \times (0.0045)) + (3 \times (0.005))] \times 0.25 = 0.90V$

- Add each devices voltage together to find the total voltage for section 1.

$$0.12V + 0.45V + 0.90V = 1.47V$$

- Find the voltages for each device in section 2 using the equation for thick cable.

$$SUM \{[(L_n \times (0.0045)) + (N_t \times (0.005))] \times I_n\} \leq 4.65V.$$

**D4**

A.  $[(200 \times (0.0045)) + (1 \times (0.005))] \times 0.25 = 0.23V$

**D5**

B.  $[(400 \times (0.0045)) + (2 \times (0.005))] \times 1.5 = 2.72V$

**D6**

C.  $[(800 \times (0.0045)) + (3 \times (0.005))] \times 0.5 = 1.81V$

- Add each devices voltage together to find the total voltage for section 2.

$$0.23 + 2.72 + 1.81 = 4.76V$$

**Result**  Since the total voltage in section 2 exceeds 4.65V, the system will not operate properly (4.76V > 4.65V).

Attempt to correct this overload by moving the power supply 91m (300ft) toward the overloaded section. Now there are 4 devices in section 1 and 2 devices in section 2. Once you've moved the power supply, try the calculations again.

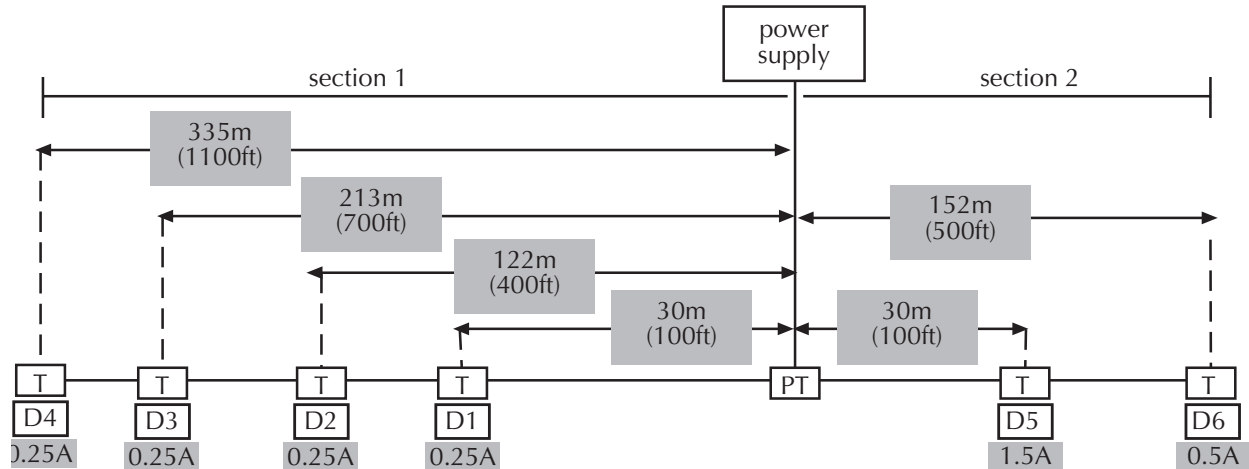

- Find the voltages for each device in section 1 using the equation for thick cable.  
 $SUM \{[(L_n \times (0.0045)) + (N_t \times (0.005))] \times I_n\} \leq 4.65V.$

- |    |  |
|----|--|
| D1 | A. $[(100 \times (0.0045)) + (1 \times (0.005))] \times 0.25 = 0.11V$  |
| D2 | B. $[(400 \times (0.0045)) + (2 \times (0.005))] \times 0.25 = 0.45V$  |
| D3 | C. $[(700 \times (0.0045)) + (3 \times (0.005))] \times 0.25 = 0.79V$  |
| D4 | D. $[(1100 \times (0.0045)) + (4 \times (0.005))] \times 0.25 = 1.24V$ |

- Add each devices voltage together to find the total voltage for section 1.

$$0.11 + 0.45 + 0.79 + 1.24 = 2.59V$$



3.  Find the voltages for each device in section 2 using the equation for thick cable.

$$SUM \{[(L_n \times (0.0045)) + (N_t \times (0.005))] \times I_n\} \leq 4.65V.$$

**D5**

A.  $[(100 \times (0.0045)) + (1 \times (0.005))] \times 1.5 = 0.68V$

**D6**

B.  $[(500 \times (0.0045)) + (2 \times (0.005))] \times 0.5 = 1.13V$

4. Add each devices voltage together to find the total voltage for section 2.  
 $0.68 + 1.13 = 1.81V$

Since the total voltage does not exceed 4.65V in either section, the system will operate properly - section 1 ( $2.59V \leq 4.65V$ )  
section 2 ( $1.81V \leq 4.65V$ ).

The percent loading is found by dividing the total voltage by 4.65V.

Section 1 %Loading =  $2.59/4.65 = 56\%$   
Section 2 % Loading =  $1.81/4.65 = 39\%$



## Selected NEC Topics

### What's in The Appendix

The following topics from the National Electric Code (NEC) section 725 (revision 1993) are known to impact the configuration and installation of DeviceNet systems in the United States. There may also be additional NEC sections and local codes that must be met. Other codes exist outside of the United States that may also affect your installation.

### Specifying Section 725 Topics

- power limitations of Class 2 circuits
  - the power source for Class 2 circuits must be either inherently limited, thus requiring no overcurrent protection, or limited by a combination of a power source and overcurrent protection
- marking
  - Class 2 power supplies must be durably marked where plainly visible to indicate the class of the supply and its electrical ratings
- interconnection of power supplies
  - Class 2 power supplies must not be paralleled or otherwise interconnected unless listed for such applications



## TROUBLESHOOTING DEVICENET

### Examine the System Design of the Installation

DeviveNet will not function correctly if design rules are not followed. Even a network previously thought to be functioning correctly may begin to exhibit anomalous operation due to incorrect system design.

- walk the network if possible to determine the actual layout
- check number of nodes
- check the cumulative drop length
- check individual drop lengths
- check branched drop lengths
- check the total trunk length, including long drop near the ends
- check the termination location and measure the terminators
- check the power supply cable length and gauge
- check for one and only one earth ground of the V-and shield
  - Break the combined shield/V-connection to frame ground and verify  $> 10M\Omega$  to frame ground
- check for one and only one V- to shield connection
  - break the shield/V-connection at the power supply and verify  $>1M\Omega$  shield to V- with 24V off
- check for shorts of CAN- and or CAN+ to shield or V-
  - verify with ohm meter
- check the length and gauge of the earth ground connection
- check the total power load and its distribution points

### Check the power

- check for trunk and drop cable type
- measure the 24V supply at the middle and ends of the network
- consider spot checking the power for noise with an oscilloscope

### Check the wiring

- check lead dress in junction boxes
- check that connectors are screwed tightly
- check that glands are screwed tightly
- check for foreign material (electrical tape, RV etc.) in glands
- check that nodes are not touching extremely hot or cold surfaces
- check that cables are kept a few inches away from power wiring
- check that cable are not draped on electrical motors, relays, contractors or solenoids
- check that cables are not constrained so as to place excessive tension on connectors
- wiggle connectors to find intermittents



### Check the scanner configuration

- check the scan list, baud rate, address and series/rev of the scanner

### Check the nodes

- drop the 24V supply, re-power and reset the scanner to initialize the network examine the scanner display codes to identify problem nodes

*at these problem nodes:*

- blinking green means node is not being allocated by the scanner
  - check that node is in the scan list
  - check the scanner is not bus off
  - check id connection is timing out
- blinking red means no communication
  - check missing power on all other nodes
  - check if all other nodes are disconnected
  - check node baud rate (bad baud rate does not always bus off)
  - check scanner, if it is bus off, this has interrupted communications - connection with the node has then timed out. Recycle 24V supply and then reset scanner. If scanner goes bus off again, problem is some combination of
    - defective node
    - Bad node baud rate
    - bad topology
    - \* bad connections
    - bad scanner
    - bad power
    - bad grounding
    - bad electrical noise
- solid red right at power up means two nodes have the same address
- Solid red after allocation means bus off
  - check baud rate
  - if symptom persists, replace node (be sure to address and ser baud rate on the replacement)
  - if symptom persists, replace tee tap
  - if symptom persists, check topology
  - if symptom persists, check power of noise with oscilloscope or power disturbance analyzer



### Points to remember

- Pressing the reset button on the scanner does not reset the network. Cycling the rack power does not reset the network power (and perhaps some critical nodes such as a scanner) does reset the network.
- Bus off (solid red) condition can only be cleared by cycling the 24V power on products without reset switches
- Cycling power on the network can cause the scanner to go bus off
- On Some DeviceNet nodes (such as photoelectric sensors) the bus off (solid red) condition can be cleared by cycling the 24V power or by pressing a reset button once or twice.
- Extreme care must be given to the task of setting initial addresses and baud rates because one incorrect node can cause other nodes to appear to be bad (solid red)
- If the scanner is bus off, nodes will not necessarily reallocate (they will stay flashing green or red) even if they are functioning correctly
- DeviceNet management and diagnostic tools can be used to identify the functioning nodes on the network, and their type. When devices are reset or re-power they will transmit two Duplicate MAC-ID request messages which provide a convenient method of verifying baud rate, MAC-ID, Vendor ID, and Serial Number of the device.
- If a node goes bus off (solid red indicator), and is replaced and still goes bus off, the problem is not the node but rather the setting of the address or baud rate OR a network wide problem related to topology, grounding, electrical noise or in intermittent node
- Intermittent power connections to nodes will provoke frequent (but perhaps incomplete) duplicate MAC-ID checks and possibly cause other nodes to go off. Intermittent data connections to a strobed node will cause corrupted frames that also may also cause other nodes to go bus off. *The source of the difficulty may be far from the node which evidences the symptom.*